



M300 Slipswitch

UNDERSPEED MOTION MONITOR



APPROVED
Class II Div.1

INSTALLATION INSTRUCTIONS

OPERATION MANUAL

Part No.'s - M3003V10C

www.go4b.com

TABLE OF CONTENTS

CUSTOMER SAFETY RESPONSIBILITIES	Page 3 - 4
PRODUCT OVERVIEW	Page 5
SPECIFICATIONS	Page 5 -6
DIMENSIONS	Page 7
INSTALLATION	Page 7 - 8
STANDARD WIRING DIAGRAM	Page 8
SENSOR CALIBRATION	Page 9
TESTING & COMMISSIONING	Page 10
TROUBLESHOOTING GUIDE	Page 10
PRODUCT WARRANTY	Page 11

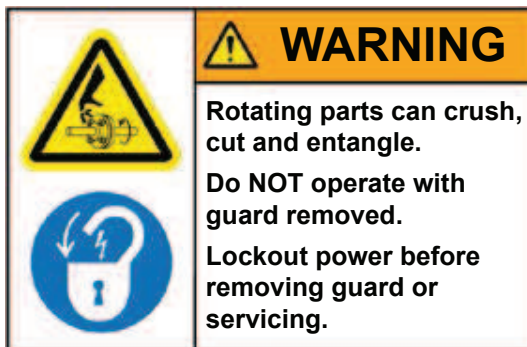

Dear 4B Customer:

Congratulations on your purchase. 4B appreciates your business and is pleased you have chosen our products to meet your needs.

Please read in its entirety and understand the literature accompanying the product before you place the product into service. Please read the safety precautions carefully before operating the product. With each product you purchase from 4B, there are some basic but important safety considerations you must follow to be sure your purchase is permitted to perform its design function and operate properly and safely, giving you many years of reliable service. Please read and understand the Customer Safety Responsibilities listed below. Failure to follow this safety directive and the Operation Manuals and other material furnished or referenced, may result in serious injury or death.

SAFETY NOTICE TO OUR CUSTOMERS

- A. In order to maximize efficiency and safety, selecting the right equipment for each operation is vital. The proper installation of the equipment, and regular maintenance and inspection is equally important in continuing the proper operation and safety of the product. The proper installation and maintenance of all our products is the responsibility of the user unless you have asked 4B to perform these tasks.
- B. All installation and wiring must be in accordance with Local and National Electrical Codes and other standards applicable to your industry. The installation of the wiring should be undertaken by an experienced and qualified professional electrician. Failure to correctly wire any product and/or machinery can result in the product or machine failing to operate as intended, and can defeat its design function.
- C. Periodic inspection by a qualified person will help assure your 4B product is performing properly. 4B recommends a documented inspection at least annually and more frequently under high use conditions.
- D. Please see the last page of this manual for all warranty information regarding this product.

CUSTOMER SAFETY RESPONSIBILITIES

1. READ ALL LITERATURE PROVIDED WITH YOUR PRODUCT

Please read all user, instruction and safety manuals to ensure that you understand your product operation and are able to safely and effectively use this product.

2. YOU BEST UNDERSTAND YOUR NEEDS

Every customer and operation is unique, and only you best know the specific needs and capabilities of your operation. Please go to www.go4b.com or call the 24-hour hotline at +1-309-698-5611 for assistance with any questions about the performance of products purchased from 4B. 4B is happy to discuss product performance with you at any time.

3. SELECT A QUALIFIED AND COMPETENT INSTALLER

Correct installation of the product is important for safety and performance. If you have not asked 4B to perform the installation of the unit on your behalf, it is critical for the safety of your operation and those who may perform work on your operation that you select a qualified and competent electrical installer to undertake the installation. The product must be installed properly to perform its designed functions. The installer should be qualified, trained, and competent to perform the installation in accordance with local and national electrical codes, all relevant regulations, as well as any of your own standards and preventive maintenance requirements, and other product installation information supplied with the product. You should be prepared to provide the installer with all necessary installation information to assist in the installation.

4. ESTABLISH AND FOLLOW A REGULAR MAINTENANCE AND INSPECTION SCHEDULE FOR YOUR 4B PRODUCTS

You should develop a proper maintenance and inspection program to confirm that your system is in good working order at all times. You will be in the best position to determine the appropriate frequency for inspection. Many different factors known to the user will assist you in deciding the frequency of inspection. These factors may include but are not limited to weather conditions; construction work at the facility; hours of operation; animal or insect infestation; and the real-world experience of knowing how your employees perform their jobs. The personnel or person you select to install, operate, maintain, inspect or perform any work whatsoever, should be trained and qualified to perform these important functions. Complete and accurate records of the maintenance and inspection process should be created and retained by you at all times.

5. RETAIN AND REFER TO THE OPERATION MANUAL FOR 4B'S SUGGESTED MAINTENANCE AND INSPECTION RECOMMENDATIONS

As all operations are different, please understand that your specific operation may require additional adjustments in the maintenance and inspection process essential to permit the monitoring device to perform its intended function. Retain the Operation Manual and other important maintenance and service documents provided by 4B and have them readily available for people servicing your 4B equipment. Should you have any questions, please call go to www.go4b.com or call the 24-hour hotline at +1-309-698-5611.

6. SERVICE REQUEST

If you have questions or comments about the operation of your unit or require the unit to be serviced please contact the 4B location who supplied the product or send your request go to www.go4b.com or call the 24-hour hotline at +1-309-698-5611. Please have available product part numbers, serial numbers, and approximate date of installation. In order to assist you, after the product has been placed into service, complete the online product registration section which is accessed via our website www.go4b.com.

WARNING

- Rotating machinery can cause serious injury or death
- Always lockout and tagout the machine prior to installation

PRODUCT OVERVIEW

The M300 Slipswitch is a simple inductive proximity shaft speed monitoring device with an adjustable 0 - 30 second start-up delay, all housed in a 30 mm diameter moulded body. The self-contained unit has a single set point, which signals when the shaft speed has dropped by 20% of normal running speed (or 10% if part number ends with “-10P”). It is used for detecting dangerous slow down and underspeed conditions on conveyors, bucket elevators, air locks, mixers, fans, grinders and many other machines.

No connection is necessary between the sensor and the equipment being monitored. The proximity sensor detects a stud or bolt mounted on a shaft, or other suitable target. Ideally, the target should be of ferrous metal, but non-ferrous metal will be detected at a shorter range. Maximum range of ferrous targets is 8 mm (5/16”) and for non-ferrous targets is 5 mm (3/16”), assuming a 20 mm (3/4”) diameter target. Smaller targets may be used but operating distances will be reduced.

SPECIFICATIONS

Supply Voltage:	24 to 240 VAC/VDC
Supply Fusing:	Supply to be fused at 500mA maximum
Switching Capacity:	M3003V10C: 100 mA maximum;
Saturation Voltage:	M3003V10C: 5.5 Volts maximum (output on);
Leakage Current:	M3003V10C: 1.6 mA maximum (output off);
Ambient Temperature:	5°F (-15°C) to +122°F (+50°C)
Output State:	M3003V10C: FET Contact closed above 80% set speed Contact opens at 20% (10% for part number ending in “-10P”)
Sensing Range:	5/16” (8 mm) maximum on ferrous metal at 77°F (25°C)
Input Pulse Range:	10 to 3,600 pulses per minute (PPM) maximum
Start-Up Delay:	Adjustable - 0 to 30 seconds
Trip Point:	20% below set speed (10% for part number ending in “-10P”)
Enclosure:	GRILON POLYAMIDE - ISO threaded 30 mm by 1.5 mm pitch
Relative Humidity:	90% RH
LED Indicators:	Blue - Target Sensed, Green - Set Speed
Connections:	M3003V10C: 2 wire, 3m long cable
Protection:	IP66

APPROVALS

M3003V10C Approvals Information

CSA

ClassII Division1 Groups E,F&G

DIMENSIONS

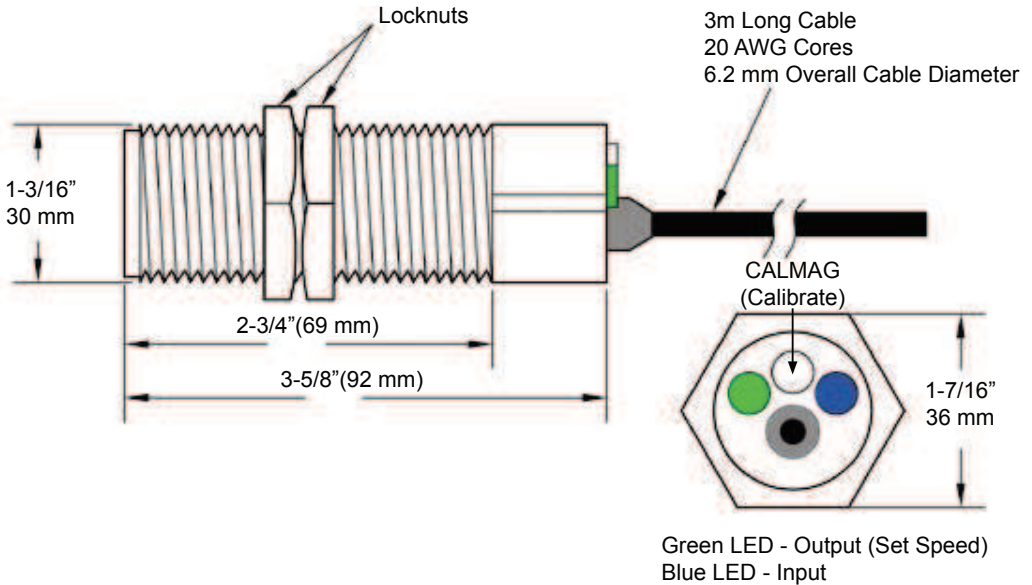

INSTALLATION

The M300 Slipswitch should be wired as indicated by the connection diagram.

The M300 Slipswitch must be wired through a load/resistor (see standard wiring diagram) and not directly to supply voltage. The supply polarity is not important and the load can be connected in either wire.

Do not wire the M300 Slipswitch to a motor starting coil.

It is not recommended to wire the M300 Slipswitch in series with other sensors.

The cable on the M300 Slipswitch can be extended to virtually any length in ordinary 2 wire or 5 wire cable.

Two locknuts are provided to mount the M300 Slipswitch in position. Mount securely to withstand vibration.

Ensure that the unit and target are adequately guarded (refer to page 8).

	WARNING
	Rotating parts can crush, cut and entangle. Do NOT operate with guard removed. Lockout power before removing guard or servicing.

WARNING

O.S.H.A. requires that all exposed rotating shafts are provided with a full guard. Therefore, this device and its target must be equipped with a guard.

Fasten the M300 to a suitable mounting bracket, such as 4B's Whirligig® universal shaft sensor mount, with the nose of the switch within the sensing range of the target, as shown below -



STANDARD WIRING DIAGRAM (M3003V10C)

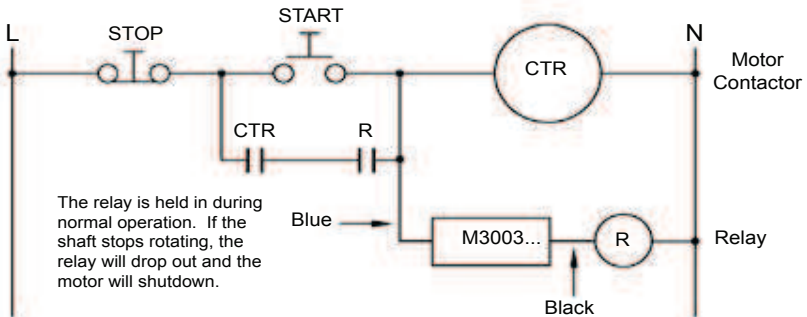
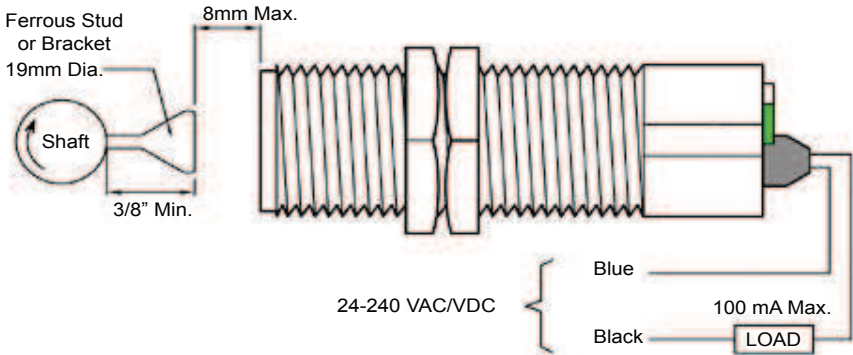

⚠ WARNING

Do NOT recalibrate sensor due to belt slipping issues.

SENSOR CALIBRATION

The M300 Slipswitch is factory calibrated at a set speed of 10 PPM and a start-up delay of 5 seconds. The sensor must be calibrated for your equipment, see "INITIAL SENSOR CALIBRATION".

INITIAL SENSOR CALIBRATION -

1. Check that the M300 is correctly installed (see standard wiring diagram).
2. Check that the distance between target, stud or bolt head and sensing face of unit is within the maximum distance specified.
3. With the belt tight and without introducing any product into the machine, start up machine. Allow machine time to attain normal running speed. The blue input LED should be flashing, if not see fault table at the bottom of the page.
4. Place the magnet (supplied with unit) on "CALIBRATE" point located at the bottom of the sensor. Each flash of the green LED represents one second for the start-up delay. Remove the magnet when the required start up delay has been achieved.
5. The green set LED will flash to 'echo' back the set time and will automatically calibrate the alarm and shutdown speeds. When the calibration is complete, the green set LED should be on steady and the blue input LED should be flashing.

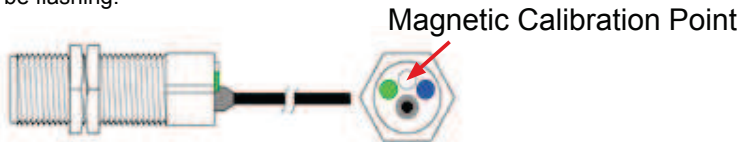

SENSOR RECALIBRATION -

If the M300 is to be used at a different machine speed or with a slower/longer time delay than previously calibrated, the unit may trip out before it can be calibrated. This can be avoided by applying power while holding the magnet on the "CALIBRATE" point and removing the magnet only when the machine has reached normal speed. Wait for the green LED to illuminate permanently and then recalibrate using steps 1 - 5 in the "INITIAL SENSOR CALIBRATION" procedure above.

TESTING AND COMMISSIONING

1. Check that the unit is correctly installed (see standard wiring diagram).
2. Check that the distance between the target, stud or bolt head and sensing face of M300 is within the minimum distance specified.
3. Start up machine, and wait for start-up delay to complete (set LED will be solid green).
4. 4B's *SpeedMaster™* calibration and testing device can be used to accurately test the shutdown features of the M300. A metal putty knife or a small piece of metal can be used to simulate a stop motion situation by placing the metal between the sensing face of the M300 and the target. After the initial start up delay, the machine should shutdown.

SPEEDMASTER™



The *SpeedMaster™* with Pulse Pilot is the only device that accurately tests the calibration of a speed switch, and allows testing of the alarm and shutdown features of the sensor while installed on the machine shaft.

The *SpeedMaster™* operates in two modes. Input mode is used to measure the pulse rate at normal speed. Output mode will allow the user to input pulses to the sensor for testing purposes.

The Pulse Pilot fits between the gap between the sensor and the target. The Pulse Pilot will have no effect on the operation of the speed switch until it is connected to the *SpeedMaster™* and set to "output" mode.

WARNING

If the system does not immediately shutdown as expected or alarm as required, then remove the machine from service until the problem has been diagnosed and corrected.

TROUBLESHOOTING GUIDE

FAULT	REMEDY
Set LED is OFF; Input LED is pulsing	Currently measured speed is more than 20% (10% for part number neding in "-10P") below the calibrated speed. Check machine speed is correct and belt is not slipping. If needed, recalibrate sensor (see page 9).
Input LED does not illuminate	Check that you have a supply of the correct value across the blue and black (M3003) wires. Slide a screwdriver blade across the face of the sensor, the input LED should flicker. If not, contact 4B. If the input LED does flicker, move the front face of the sensor closer to the target and check the target size as specified under "INSTALLATION".
Input LED Stays on Permanently	Either increase the gap between the target and the shaft, or between the target and the sensor face.

PRODUCT WARRANTY

1. EXCLUSIVE WRITTEN LIMITED WARRANTY

All products sold are warranted by the company 4B Components Limited, 4B Braime Components Limited, and 4B France herein after referred to as 4B to the original purchaser against defects in workmanship or materials under normal use for one (1) year after date of purchase from 4B. Any product determined by 4B at its sole discretion to be defective in material or workmanship and returned to a 4B branch or authorized service location, as 4B designates, shipping costs prepaid, will be, as the exclusive remedy, repaired or replaced at 4B's option.

2. DISCLAIMER OF IMPLIED WARRANTY

No warranty or affirmation of fact, expressed or implied, other than as set forth in the exclusive written limited warranty statement above is made or authorized by 4B. 4B specifically disclaims any liability for product defect claims that are due to product misuse, abuse or misapplications, as authorized by law, 4B specifically disclaims all warranties that the product is fit or merchantable for a particular purpose.

3. NO WARRANTY "BY SAMPLE OR EXAMPLE"

Although 4B has used reasonable efforts to accurately illustrate and describe the products in its catalogs, literature, and websites, such illustrations and descriptions are for the sole purpose of product identification and do not express or imply a warranty affirmation of fact, of any kind or a warranty or affirmation of fact that the products will conform to their respective illustrations or descriptions. 4B expressly disclaims any warranty or affirmation of fact, expressed or implied, other than as set forth in the exclusive written limited warranty statement above, including, without limitation, the implied warranties of merchantability and fitness for a particular purpose.

4. LIMITATION OF DAMAGES

Any liability for consequential, incidental, special, exemplary, or punitive damages, or for loss of profit whether direct or indirect, is expressly disclaimed.

With subsidiaries in North America, Europe, China, Asia, Africa and Australia along with a worldwide network of distributors, 4B can provide practical solutions for all your applications no matter the location.



4B BRAIME COMPONENTS LTD.

Hunslet Road
Leeds
LS10 1JZ
United Kingdom
Tel: +44 (0) 113 246 1800
Fax: +44 (0) 113 243 5021

4B DEUTSCHLAND

9 Route de Corbie
80800 Lamotte Warfusée
France
Tel: +49 (0) 700 2242 4091
Fax: +49 (0) 700 2242 3733

4B AFRICA

14 Newport Business Park
Mica Drive, Kya Sand
2163 Johannesburg
South Africa
Tel: +27 (0) 11 708 6114
Fax: +27 (0) 11 708 1654

4B FRANCE

9 Route de Corbie
80800 Lamotte Warfusée
France
Tel: +33 (0) 3 22 42 32 26
Fax: +33 (0) 3 22 42 37 33

4B COMPONENTS LTD.

625 Erie Avenue
Morton, IL 61550
USA
Tel: 309-698-5611
Fax: 309-698-5615

4B ASIA PACIFIC

Build No. 899/1 Moo 20
Soi Chongsiri, Bangplee-Tam
Ru Road, Tanbon Bangpleeyai,
Amphur Bangplee,
Samutprakarn 10540
Thailand
Tel: +66 (0) 2 173-4339
Fax: +66 (0) 2 173-4338

4B China

F1, Building 5A,
Jintong Industrial Park,
8 West Lake Road,
Wujin High & New TDZ,
Changzhou, Jiangsu, PRC
Tel: +86-519-88556006
Email: 4b-china@go4b.com

4B AUSTRALIA

Building 1, 41 Bellrick Street
Acacia Ridge
Queensland 4110
Australia
Tel: +61 (0)7 3216 9365
Fax: +61 (0)7 3219 5837



www.go4b.com