

# INSTRUCTION MANUAL



Approvals



## Encoder-Flex 1024 Digital Rotary Encoder

Part Number: EFLEX10242V34C/x

REV013024



- EN** To download the digital version of this instruction manual and to check other available languages scan the following QR code.
- ES** Para descargar la versión digital de este manual de instrucciones y consultar otros idiomas disponibles, escanee el siguiente código QR.
- PT** Para baixar a versão digital deste manual de instruções e verificar outros idiomas disponíveis, escaneie o seguinte código QR.
- FR** Pour télécharger la version numérique de ce manuel d'instructions et pour vérifier les autres langues disponibles, scannez le code QR suivant.
- DE** Um die digitale Version dieser Bedienungsanleitung herunterzuladen und andere verfügbare Sprachen zu überprüfen, scannen Sie den folgenden QR-Code.
- RU** Чтобы загрузить цифровую версию данного руководства по эксплуатации и проверить другие доступные языки, отсканируйте следующий QR-код.
- ZH** 要下載本說明手冊的數字版本並查看其他可用語言，請掃描以下二維碼。



## TABLE OF CONTENTS

---

CUSTOMER SAFETY RESPONSIBILITIES .....	4
PRODUCT OVERVIEW .....	7
PACKAGE CONTENT .....	7
SPECIFICATIONS .....	8
APPROVALS .....	8
DIMENSIONS .....	9
SPECIFIC CONDITIONS OF USE .....	10
STANDARD WIRING DIAGRAM .....	11
INSTALLATION.....	13
OPERATION .....	14
COMMUNICATION OPTIONS .....	19
PRODUCT WARRANTY .....	27

## CUSTOMER SAFETY RESPONSIBILITIES

4B appreciates your business and is pleased you have chosen our products to meet your needs.

Please read in its entirety and understand the literature accompanying the product before you place the product into service. Please read the safety precautions carefully before operating the product. With each product you purchase from 4B, there are some basic but important safety considerations you must follow to be sure your purchase is permitted to perform its design function and operate properly and safely, giving you many years of reliable service. Please read and understand the Customer Safety Responsibilities listed below. Failure to follow this safety directive and the Operation Manuals and other material furnished or referenced, may result in serious injury or death.

### SAFETY NOTICE TO OUR CUSTOMERS

- A. In order to maximize efficiency and safety, selecting the right equipment for each operation is vital. The proper installation of the equipment, and regular maintenance and inspection is equally important in continuing the proper operation and safety of the product. The proper installation and maintenance of all our products is the responsibility of the user unless you have asked 4B to perform these tasks.
- B. All installation and wiring must be in accordance with Local and National Electrical Codes and other standards applicable to your industry. (Please see the article “Hazard Monitoring Equipment Selection, Installation and Maintenance” at [www.go4b.com/usa](http://www.go4b.com/usa)). The installation of the wiring should be undertaken by an experienced and qualified professional electrician. Failure to correctly wire any product and/or machinery can result in the product or machine failing to operate as intended, and can defeat its design function.
- C. Periodic inspection by a qualified person will help assure your 4B product is performing properly. 4B recommends a documented inspection at least annually and more frequently under high use conditions.
- D. Please see the last page of this manual for all warranty information regarding this product.

### CUSTOMER SAFETY RESPONSIBILITIES

#### 1. READ ALL LITERATURE PROVIDED WITH YOUR PRODUCT

Please read all user, instruction and safety manuals to ensure that you understand your product operation and are able to safely and effectively use this product. If the

equipment is used in a manner not specified in this manual, the protection provided by the equipment may be impaired.

## **2. YOU BEST UNDERSTAND YOUR NEEDS**

Every customer and operation is unique, and only you best know the specific needs and capabilities of your operation. Please call the 24-hour hotline at 309-698-5611 for assistance with any questions about the performance of products purchased from 4B. 4B is happy to discuss product performance with you at any time.

## **3. SELECT A QUALIFIED AND COMPETENT INSTALLER**

Correct installation of the product is important for safety and performance. If you have not asked 4B to perform the installation of the unit on your behalf, it is critical for the safety of your operation and those who may perform work on your operation that you select a qualified and competent electrical installer to undertake the installation. The product must be installed properly to perform its designed functions. The installer should be qualified, trained, and competent to perform the installation in accordance with Local and National Electrical Codes, all relevant OSHA Regulations, as well as any of your own standards and preventive maintenance requirements, and other product installation information supplied with the product. You should be prepared to provide the installer with all necessary installation information to assist in the installation.

## **4. ESTABLISH AND FOLLOW A REGULAR MAINTENANCE AND INSPECTION SCHEDULE FOR YOUR 4B PRODUCTS**

You should develop a proper maintenance and inspection program to confirm that your system is in good working order at all times. You will be in the best position to determine the appropriate frequency for inspection. Many different factors known to the user will assist you in deciding the frequency of inspection. These factors may include but are not limited to weather conditions; construction work at the facility; hours of operation; animal or insect infestation; and the real-world experience of knowing how your employees perform their jobs. The personnel or person you select to install, operate, maintain, inspect or perform any work whatsoever, should be trained and qualified to perform these important functions. Complete and accurate records of the maintenance and inspection process should be created and retained by you at all times.



## **5. RETAIN AND REFER TO THE OPERATION MANUAL FOR 4B'S SUGGESTED MAINTENANCE AND INSPECTION RECOMMENDATIONS**

As all operations are different, please understand that your specific operation may require additional adjustments in the maintenance and inspection process essential

to permit the monitoring device to perform its intended function. Retain the Operation Manual and other important maintenance and service documents provided by 4B and have them readily available for people servicing your 4B equipment. Should you have any questions, please call the 24-hour hotline number 309-698-5611, contact your local distributor, or use one of the contact ways available in our website [www.go4b.com/usa](http://www.go4b.com/usa).

## 6. SERVICE REQUEST

If you have questions or comments about the operation of your unit or require the unit to be serviced please call the 24-hour hotline number 309-698-5611, contact your local distributor, or use one of the ways available in our website [www.go4b.com/usa](http://www.go4b.com/usa). Please have available product part numbers, serial numbers, and approximate date of installation. In order to assist you, after the product has been placed into service, complete the online product registration section which is accessed via our website [www.go4b.com/usa](http://www.go4b.com/usa).

 <b>WARNING</b>	
 	<p>Moving parts can crush and cut.</p> <p>Lockout power before removing guard or servicing.</p> <p>Do NOT operate with guard removed.</p>

## PRODUCT OVERVIEW

The Encoder-Flex 1024 is a rotary shaft encoder designed to detect shaft speed, shaft position, gate position, and shaft direction. This solid-state encoder features electronics that are potted and totally sealed in a stainless steel body and are completely mechanically isolated from the rotating shaft. Because the shaft does not enter the sensor body, there are no entry points for moisture and dust ingress.

The Encoder-Flex 1024 comes standard with Modbus RTU communications and can be programmed from 1 to 1024 targets per revolution with free PC software. This software also provides a dashboard of the sensor position and calibrated parameters. The running mode and calibration can be configured using the free software or included calibration magnet.

The Encoder-Flex 1024 is powered via a 12-24 VDC supply and provides the following outputs:

- Quadrature Pulse (Speed/Relative Rotation)
- 4-20mA or 0-20mA (Speed/Absolute Position/Multi-Turn Absolute Position)
- RS485 Modbus (All Properties)

The quadrature pulse output is a normally dual-channel signal that can be used with a PNP or NPN input device. See “PNP Pulse Output Wiring Example” for a sample PNP wiring diagram using just the A channel.

## PACKAGE CONTENT

1 x Encoder-Flex 1024



1 x Setup and calibration magnet



1 x High flex securing strap



1 x Instruction manual

## SPECIFICATIONS

Operating Voltage Range	12 VDC to 24 VDC (Optimal) – 26.2 VDC max
Power Max	2W
Speed Range	0-2,000 RPM
Outputs	<ul style="list-style-type: none"> <li>• 4-20mA or 0-20 (21mA Max, 330Ω Max)</li> <li>• Quadrature (500Hz Max)</li> <li>• Pulse (500Hz Max)</li> <li>• Modbus RTU (RS485 115200 bps)</li> </ul>
Resolution	Adjustable 1 to 1024 Pulses Per Revolution
Enclosure	304 Stainless Steel
Shaft Type	<ul style="list-style-type: none"> <li>• M12 (EFLEX10242V34C/0)</li> <li>• 1/2" – 13 UNC (EFLEX10242V34C/1)</li> <li>• D-Type (EFLEX10242V34C/2)</li> <li>• 3/8" - 16 UNC (EFLEX10242V34C/3)</li> </ul>
Operating Temperature	-30°C (-22°F) to +50°C (122°F)
Cable	9 ft. (3m) – Shielded 8 Conductor + Bare Earth
Calibration	Magnetic or PC Software
Conduit Entry	1/2" NPT
Weight	1.8lbs (0.8kg)

## APPROVALS



**US & Canada: EFLEX1024....C...**

Class II Division 1 Groups E,F&G T<sub>200</sub>100°C

AEx / Ex ta IIIC T<sub>200</sub>100°C Da IP66

-30°C ≤ Ta ≤ +50°C

MET Labs listing – E115704

# DIMENSIONS

NOTE: Dimensions are in Inches

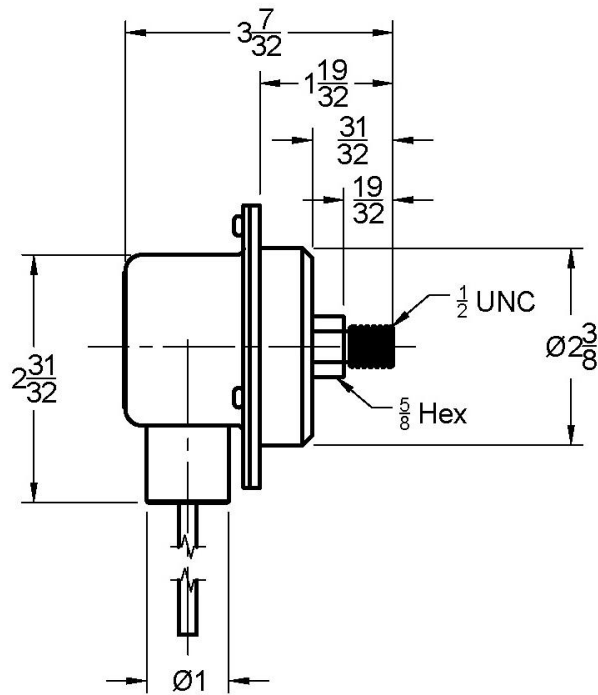
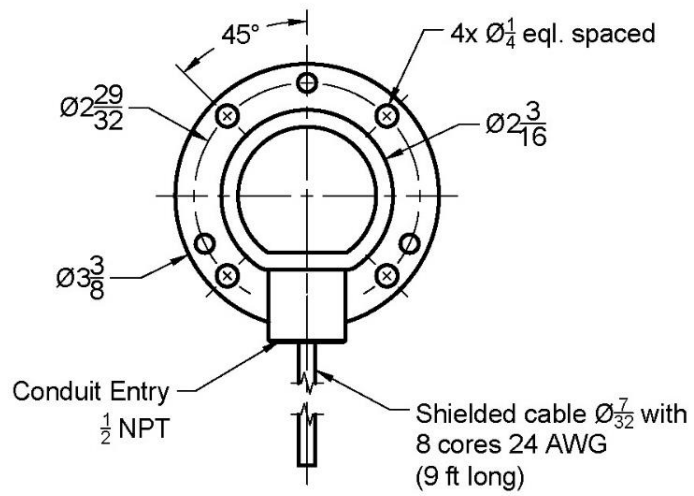

## SPECIFIC CONDITIONS OF USE

---

1. The Encoder-Flex 1024 shall be connected to a suitable external earth via the mounting holes or via the mounting screws and a suitable ring crimp.
2. The integral cable shall be terminated in a suitably certified enclosure or in a safe area.
3. The supply circuit of the system where the equipment is connected shall be protected by a suitably rated fuse capable of interrupting a prospective short circuit current of 1.5 kA.

# STANDARD WIRING DIAGRAM

All wiring must be in accordance with local and national electrical codes and should be undertaken by an experienced and qualified electrician.

If required by local installation code, use dust/liquid tight flexible metal conduit with approved fittings to protect the sensor cables.

If required, mount a suitable junction box within the supplied length of the product's cable and (if required, using a suitable conduit to protect the cables) make the necessary wiring connections inside this junction box.

## Encoder Wire Description

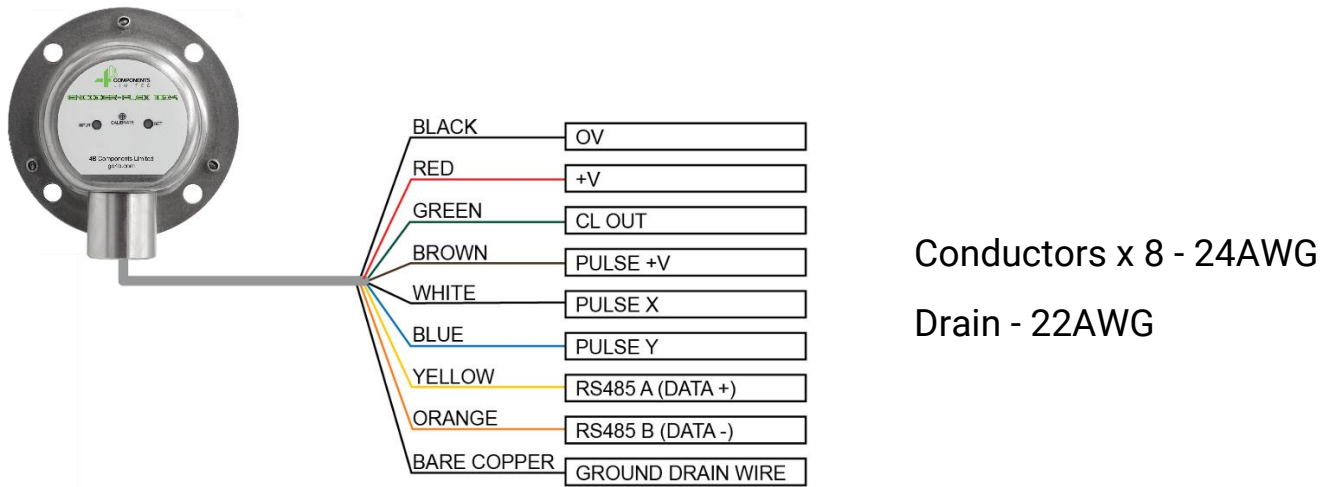

## PNP Pulse Output Wiring Example

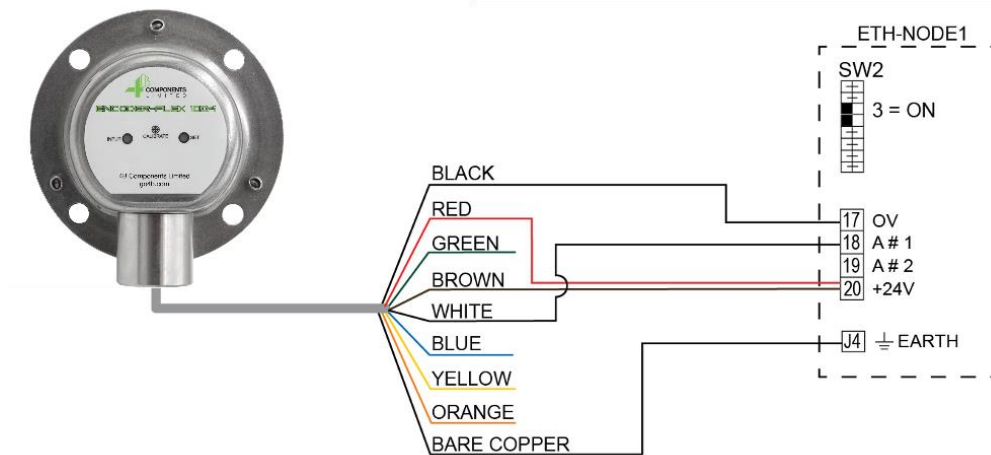

## Current Loop Output Wiring Example

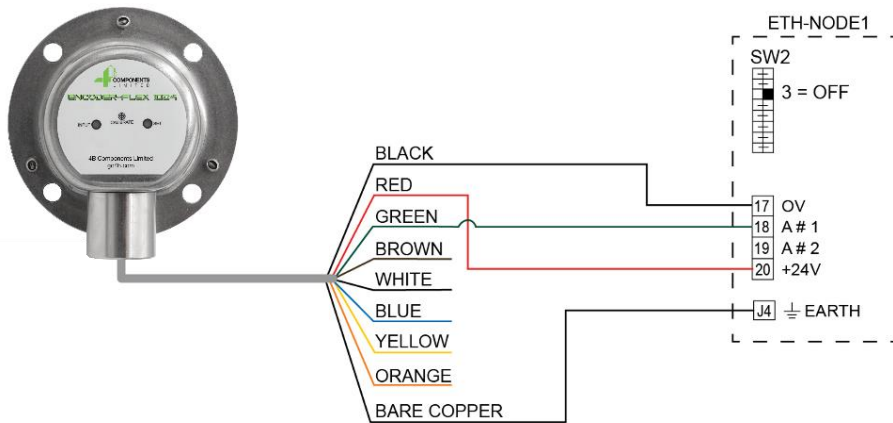

## PTD110V6 Wiring Example

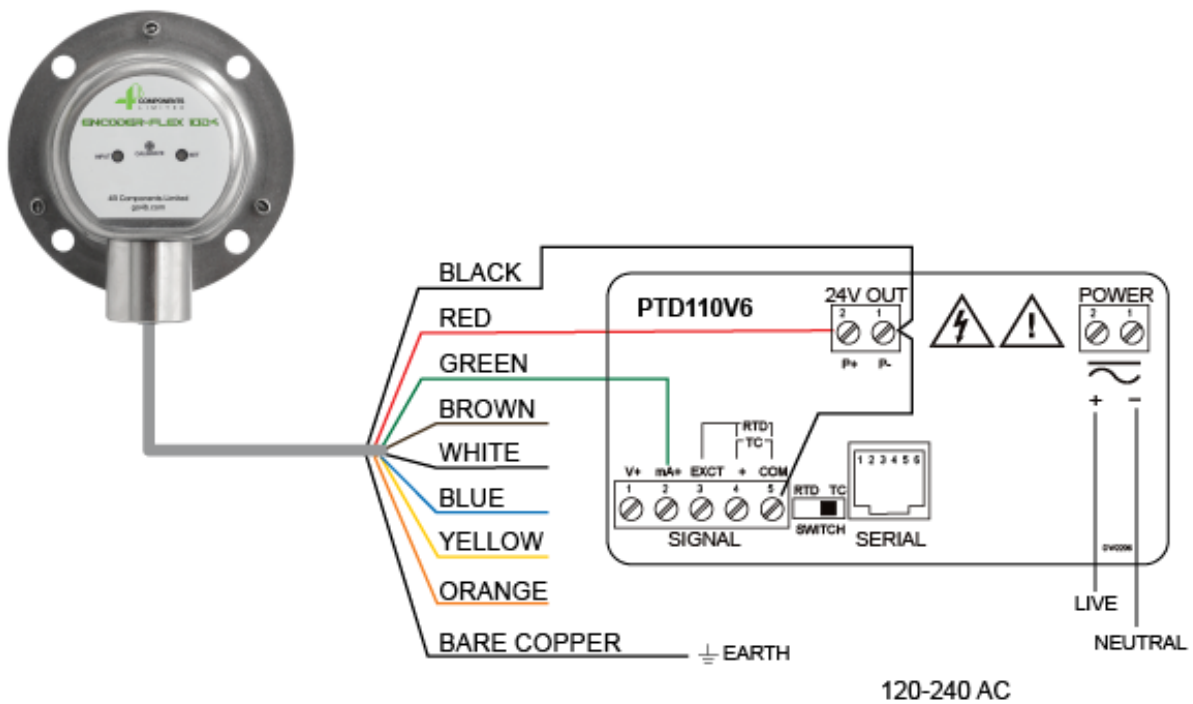

PTD110V6  
Programing  
Instructions



# INSTALLATION

The Encoder-Flex 1024 should be mounted to a rotating shaft using the threaded or D-profile shaft of the encoder. A belt or bracket can be mounted onto the two recessed screw threads and this can be used to provide further mechanical support but is primarily for the purpose of stopping slight movements in the device housing. All installations must conform to the local electrical wiring regulations (such as NEC, CEC, EN IEC 60079-14).

The below instructions are given in metric to match the hardware provided with the sensor. The mounting holes for the M6 bolts are thru holes and can be mounted on either side.

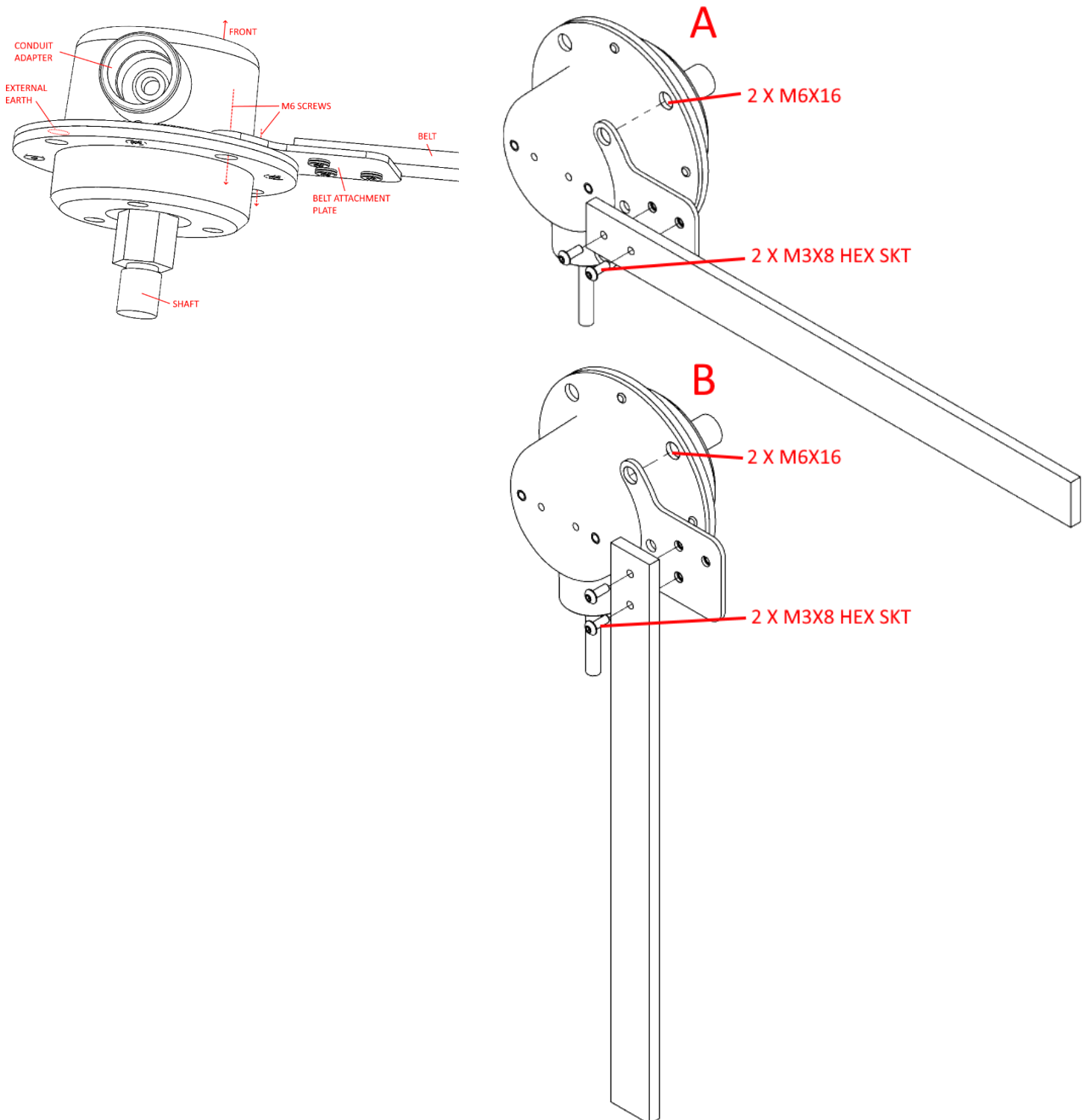

## Layout

The Encoder-Flex 1024's interface consists of two bi-color (red/green) LED's labeled Input and Set. Additionally, in the center of the device is a magnetic target (labeled CALIBRATE) which can be used to control the operating mode and calibration. A special calibration magnet is supplied, but any dual pole magnet can be used.



## Startup Operation

When powered on, the LED marked (SET) should flash green three times, the LED marked (INPUT) shows the step progress so may or may not be red.

## Operating Modes

The Encoder-Flex 1024 has 3 main operating modes:

- Multi-Turn (Gate Position) – Set LED solid red.
- Continuous Angle – Set LED solid green.
- Speed Mode – Set LED fast green blink.

Each one of these modes has an Analog (current loop) output that is calibrated when the mode is selected.

### MULTI-TURN (GATE POSITION)

Multi turn mode allows the device to be set up to measure proportional angular position over a number of rotations of the shaft. During normal operation if a **North Pole** of a magnet is held over the calibration point, the mode is switched to Multi Turn Configuration. This sets the start point for the multi turn operation so the shaft the encoder is connected to should be in its starting location. For example, a gate should be fully closed(4mA). The user should then operate the machine to its end point, in the case of a gate this would be fully open (20mA).

The user then should use the **North Pole** of a magnet on the calibration point once more and the end point will be set. The encoder will now continue to monitor the shaft and will keep track of the proportion of movement between the start and end points.

The 4-20mA current output is linearly proportional to the current position of the operating machine. In the event the machine operates past the limits set on the device the output will remain locked to 0% (4mA) or 100% (20mA).

If the machine/shaft is moved when power is disconnected from the Encoder-Flex 1024 then the device will be able to continue to keep track when powered back on up to half a turn on the shaft. If the machine/shaft is moved further than this without power then the Encoder-Flex 1024 will need to be recalibrated for Multi Turn in the method previously described.

### **CONTINUOUS ANGLE (360°)**

Continuous angle mode indicates that the device will keep track of the angle of the device's shaft. The zero of the shaft's rotational angle is set when this mode is switched to by using the **South Pole** on the calibration point.

The output of the 4-20mA current loop when the current output mode is set to Auto (default) will be proportional to the current angle relative to the users set zero point, e.g.

- 0 degrees = 4mA
- 90 degrees = 8mA
- 180 degrees = 12mA
- 240 degrees = 16mA
- 360 degrees = 20mA

If the shaft goes through a full rotation, it will roll over from 360° (20mA) back to 0° (4mA).

### **Speed Mode**

Speed mode works in a similar manner to continuous angle. The main difference being that the 4-20 mA current loop will react to rotational speed relative to a calibrated speed. This mode is accessed by holding the **South Pole** of a magnet over the calibration point.

Once Speed mode is selected, the device will calibrate the 4-20 mA current loop output based on the shaft speed at that moment. As such it is recommended to first leave the device in Angle mode, turn on the machine and wait until it achieves 100% speed before finally using the magnet to set Speed mode.

Once calibrated in this way the 4-20mA output in Auto current mode will display the following behavior:

- 4mA = 0% speed
- 17mA = 100% speed
- 20mA = 123% speed

The current output is linearly proportional to the speed with 17mA representing 100% of the speed.

### Pulse/Quadrature Output

The pulse/quadrature outputs will always output in all 3 modes. The input LED will match what is currently on the pulse channel A. The pulse rate is determined by the PPR (pulse per revolution) that can only be set using the software interface. The default PPR is 64.

During an error state the set LED will flash several times in sequence. And the output may not act as expected. This flash can be green or red. If this occurs, please note the color and number of flashes that are repeating and contact 4B for further instructions.

### Changing Mode

The operating mode of the Encoder-Flex 1024 can be switched using the magnetic target input on the front of the device or via the RS485 Modbus connection (or GUI).







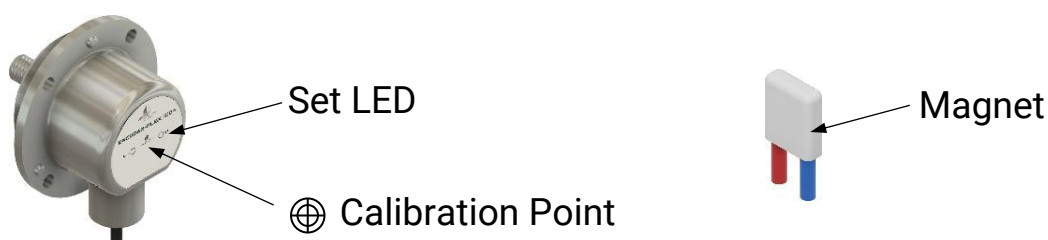





The magnetic target can detect the difference between the **North Pole** or **South Pole** of a magnet that is applied to it. Apply the magnet for 5 seconds or until the SET LED behavior changes. The information ahead will explain when a **North Pole** or **South Pole** should be used.

### Magnetic Setup

#### Encoder-Flex 1024 Mode Selection and Calibration with magnet (4-20 mA Output)







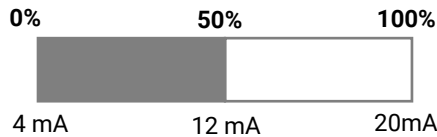

## 1. MULTI-TURN MODE (GATE POSITION)

Action		Set LED feedback (Red)
1.1	Turn the shaft to the start position	
1.2	 Place the red magnet (N) on the calibration point	
1.3	 Hold the magnet in place for 3 seconds	
1.4	 Remove the magnet.	 4 mA is set
1.5	Turn the shaft to the end position	
1.6	 Place the red magnet (N) on the calibration point	
1.7	 Hold the magnet in place for 3 seconds	
1.8	 Remove the magnet.	 20 mA is set



4-20 mA Scale





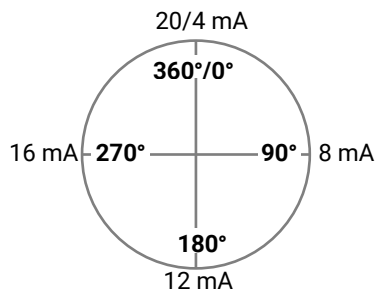

## 2. CONTINUOUS ANGLE MODE (360°)

Action		Set LED feedback (Green)
2.1	Turn the shaft to the start position (0°)	
2.2	 Place the blue (S) magnet on the calibration point	
2.3	 Hold the magnet in place for 3 seconds	
2.4	 Remove the magnet.	 4-20 mA is set
2.5	If light pattern matches as shown perform steps 2.1-2.4 again.	



4-20 mA Scale

### 3. SPEED MODE

	Action	Set LED feedback (Green)	
3.1	Turn on the machine and wait until it achieves 100% speed.		
3.2	 Place the blue magnet (S) on the calibration point		
3.3	 Hold the magnet in place for 3 seconds		
3.4	 Remove the magnet.		4-20 mA is set
Note	If light is solid green preform steps 3.1-3.4 again.		

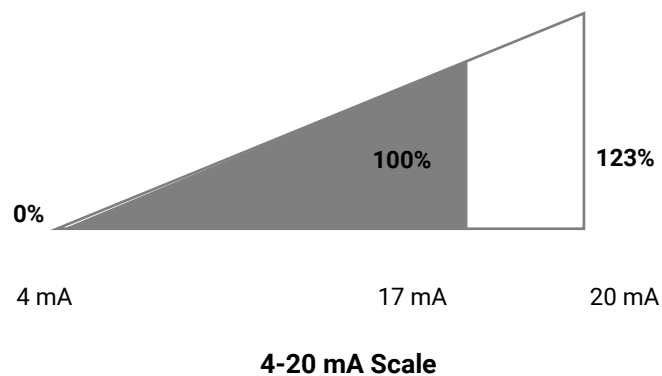

NOTE

During boot up the set LED will flash green 3 times. This lets you know all systems are normal.

Mode Cycle Flow Chart

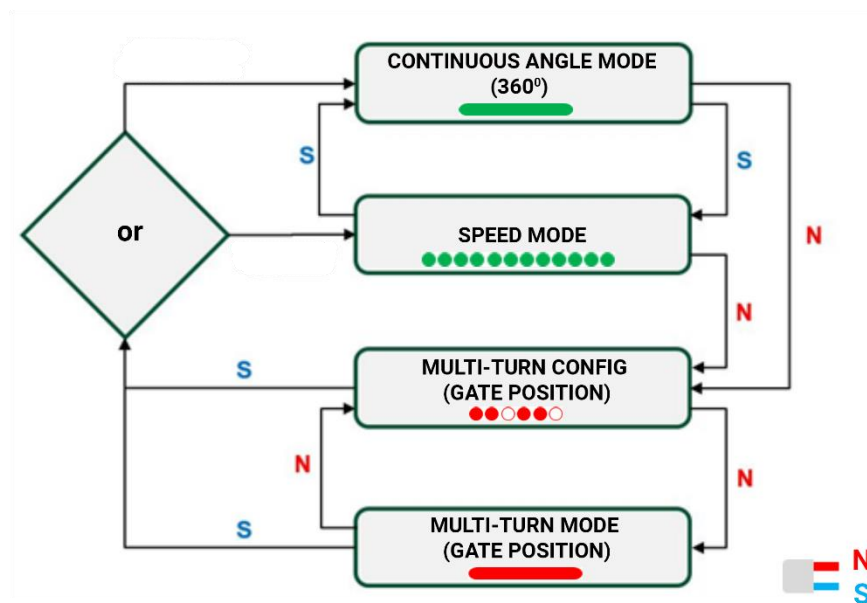

## RS485 Modbus

The unit supports Modbus (RTU) based communications over an RS485 half-duplex connection through the orange and yellow wires in the cable. A description of available registers can be found in the associated Communications Support Document. Configuration is limited in this mode, the GUI (see below) should be used to remotely configure/calibrate the encoder.

## Encoder-Flex 1024 Interface GUI

Additionally, the device can also be controlled via a GUI called the Encoder-Flex 1024 Configurator. This gives a live view of the current measurements as well as allowing the device to be configured with different settings.

## Connecting to Encoder

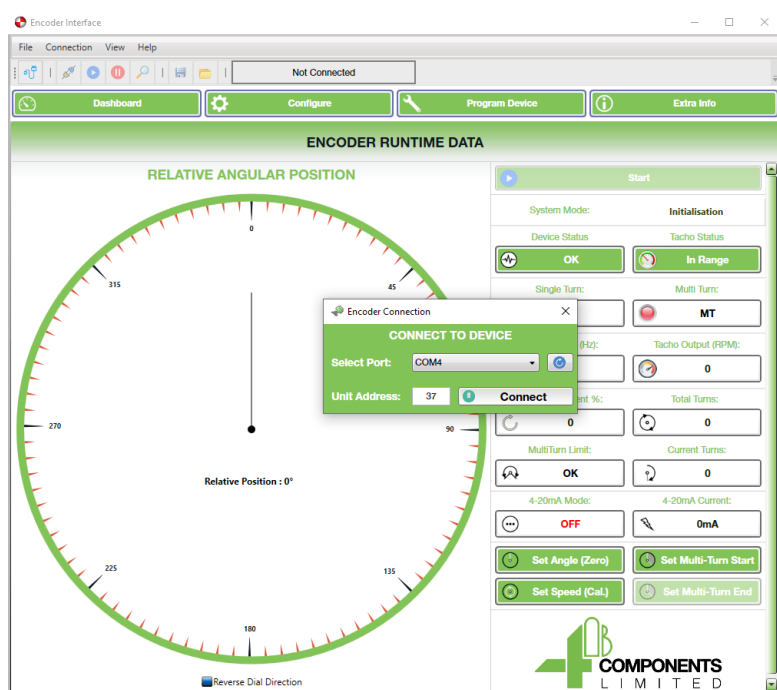

When you select the connection option it will ask you to select a port on your PC that you are using and select an address. The address is the last two digits of the serial number. The serial number is located around 4 inches down on the cable. In the example pictured below, the address is “37”.



Once connected you need to press the start button.

# Dashboard

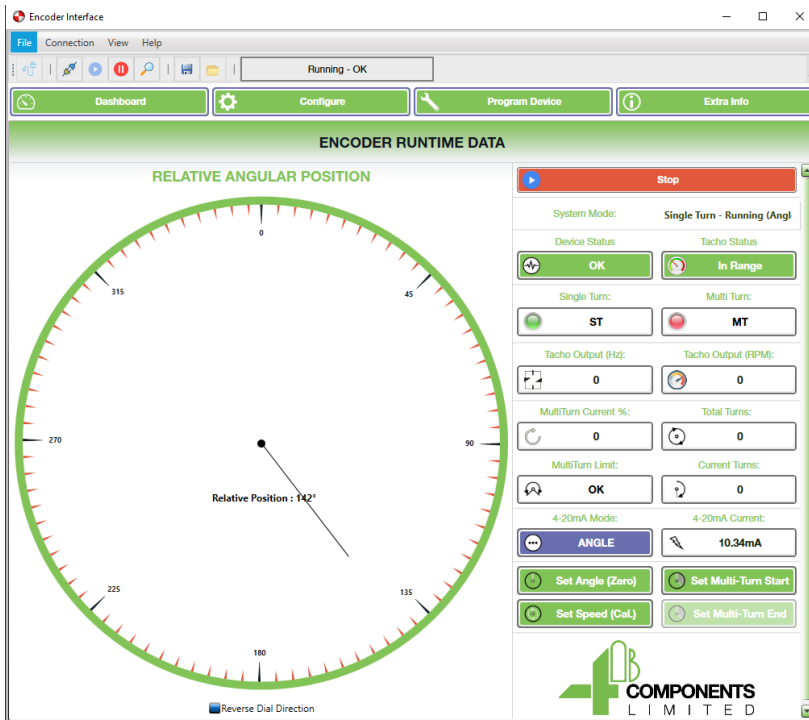

- Dial indicates shaft orientation
- 4-20 mode shows current operating mode
- Readouts for 4-20, total turns, RPM, Multi turn percentage
- Error Information
- Buttons for remotely changing modes and calibrating device

# Configure

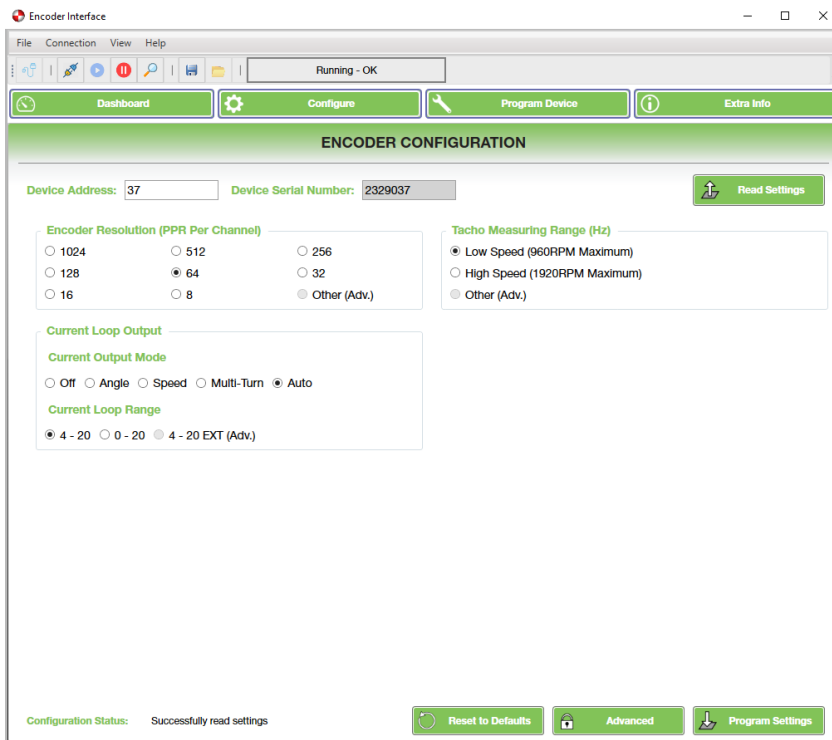

- View Device Serial Number
- Modify Device Address
- Set PPR (Encoder Resolution)
- Set Tacho (Speed) Resolution
- Change Current Output mode (Default Auto)
- Change 4-20 to 0-20
- Advanced settings for troubleshooting only – Contact 4B

Once changes are made press program settings. Encoder will remember settings even after power reset.

## Program Device

Used to update firmware. Only use when recommended by 4B. If done incorrectly or with wrong file, it may render the encoder un-usable.

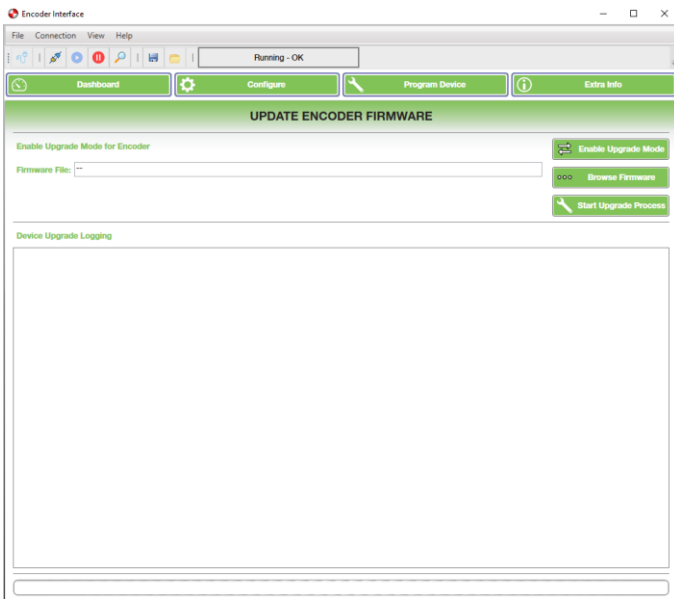

## Extra Info

The below information is available via Modbus registers as well. This information can be useful for troubleshooting purposes.

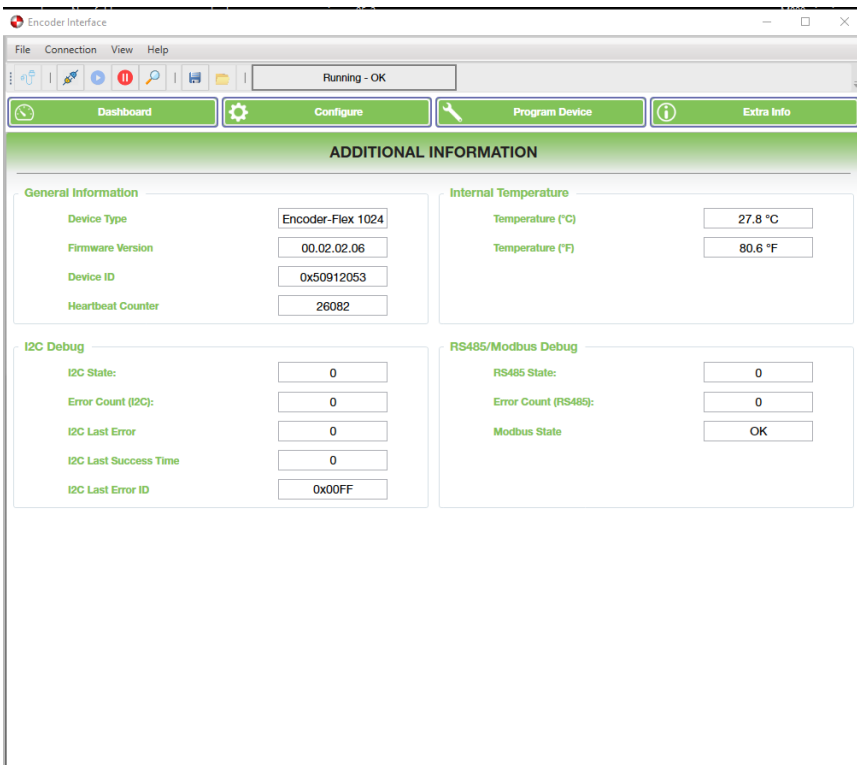

- Communication error counter
- Heartbeat counter
- Firmware version
- Internal temp of components (should not be used for ambient temp)
- RS485 debug.

## Factory Default

When selected all settings are changed to the factory default.

### ALL CALIBRATIONS WIPED

**Operating Mode:** Continuous Angle

**Tacho Range:** 960RPM

**Resolution:** 64 PPR

**Current Mode:** Auto

**Current Range:** 4-20mA

**Hysteresis:** 0

**Speed Measurement Window:** 1000ms

### **WARNING**

If the system does not immediately shutdown as expected or alarm as required, then remove the machine from service until the problem has been diagnosed and corrected.







## **1. EXCLUSIVE WRITTEN LIMITED WARRANTY**

All products sold are warranted by the company 4B Components Limited and 4B Braime Components Limited herein after referred to as 4B to the original purchaser against defects in workmanship or materials under normal use for one (1) year after date of purchase from 4B. Any product determined by 4B at its sole discretion to be defective in material or workmanship and returned to a 4B branch or authorized service location, as 4B designates, shipping costs prepaid, will be, as the exclusive remedy, repaired or replaced at 4B's option.

## **2. DISCLAIMER OF IMPLIED WARRANTY**

No warranty or affirmation of fact, expressed or implied, other than as set forth in the exclusive written limited warranty statement above is made or authorized by 4B. 4B specifically disclaims any liability for product defect claims that are due to product misuse, abuse or misapplications, as authorized by law, 4B specifically disclaims all warranties that the product is fit or merchantable for a particular purpose.

## **3. NO WARRANTY "BY SAMPLE OR EXAMPLE"**

Although 4B has used reasonable efforts to accurately illustrate and describe the products in its catalogs, literature, and websites, such illustrations and descriptions are for the sole purpose of product identification and do not express or imply a warranty affirmation of fact, of any kind or a warranty or affirmation of fact that the products will conform to their respective illustrations or descriptions. 4B expressly disclaims any warranty or affirmation of fact, expressed or implied, other than as set forth in the exclusive written limited warranty statement above, including, without limitation, the implied warranties of merchantability and fitness for a particular purpose.

## **4. LIMITATION OF DAMAGES**

Any liability for consequential, incidental, special, exemplary, or punitive damages, or for loss of profit, whether direct or indirect, is expressly disclaimed.

4B is the worldwide leading manufacturer of high-quality, technologically advanced material handling and electronic components.



## 4B Locations Around the World



### **USA**

4B Components Ltd.  
625 Erie Avenue  
Morton, IL 61550  
Tel: +1 (309) 698-5611

### **France**

4B France  
35 bis, rue du 8 mai 1945,  
Villers Bretonneux, F-80800  
Tel: +33 (0) 3 22 42 32 26

### **Australia**

4B Australia  
Building 1, 41 Bellrick St,  
Acacia Ridge 4110,  
Queensland  
Tel: +61 (0)7 3216 9365

### **United Kingdom**

4B Braime Components Ltd.  
Hunslet Road  
Leeds, LS10 1JZ  
Tel: +44 (0) 113 246 1800

### **Germany**

4B Germany  
35 bis, rue du 8 mai 1945,  
Villers Bretonneux, F-80800  
France  
Tel: +49 (0) 2333 601681

### **China**

4B China  
F1, Building 5A,  
8 West Lake Road Wujin High &  
New Technology Develop. Zone  
Changzhou 213164  
Jiangsu Province  
Tel: +86-136 0160 9266

### **Thailand**

4B Asia Pacific  
Build No.899/1 Moo 20  
Soi Chongsiri, Bangplee-Tam Ru Road  
Tanbon Bangpleeyai, Amphur Bangplee  
Samutprakarn 10540  
Tel: +66 (0) 2 173-4339

### **South Africa**

4B Africa  
14 Newport Business Park  
Mica Drive, Kya Sand  
2163 Johannesburg  
Tel: +27 (0) 11 708 6114

### **United Arab Emirates**

4B Braime Components Limited  
Sharjah International Airport Free Zone  
Saif Zone, Y Building, Office no. Y-44A  
P.O Box: SHJ-0., UAE reg. no. 23784  
Tel: +971 (0) 6 5212 044