

## WARRANTY INFORMATION

### 1. EXCLUSIVE WRITTEN LIMITED WARRANTY

ALL PRODUCTS SOLD ARE WARRANTED BY THE COMPANY (4B COMPONENTS LIMITED, (4B) BRAIME ELEVATOR COMPONENTS LIMITED, AND (4B) S.E.T.E.M. Sarl HEREIN AFTER REFERRED TO AS 4B TO THE ORIGINAL PURCHASER AGAINST DEFECTS IN WORKMANSHIP OR MATERIALS UNDER NORMAL USE FOR ONE (1) YEAR AFTER DATE OF PURCHASE FROM 4B. ANY PRODUCT DETERMINED BY 4B AT ITS SOLE DISCRETION TO BE DEFECTIVE IN MATERIAL OR WORKMANSHIP AND RETURNED TO A 4B BRANCH OR AUTHORIZED SERVICE LOCATION, AS 4B DESIGNATES, SHIPPING COSTS PREPAID, WILL BE, AS THE EXCLUSIVE REMEDY, REPAIRED OR REPLACED AT 4B'S OPTION.

### 2. DISCLAIMER OF IMPLIED WARRANTY

NO WARRANTY OR AFFIRMATION OF FACT, EXPRESSED OR IMPLIED, OTHER THAN AS SET FORTH IN THE EXCLUSIVE WRITTEN LIMITED WARRANTY STATEMENT ABOVE IS MADE OR AUTHORIZED BY 4B. 4B SPECIFICALLY DISCLAIMS ANY LIABILITY FOR PRODUCT DEFECT CLAIMS THAT ARE DUE TO PRODUCT MISUSE, ABUSE OR MISAPPLICATIONS, AS AUTHORIZED BY LAW, 4B SPECIFICALLY DISCLAIMS ALL WARRANTIES THAT THE PRODUCT IS FIT OR MERCHANTABLE FOR A PARTICULAR PURPOSE.

### 3. NO WARRANTY "BY SAMPLE OR EXAMPLE"

ALTHOUGH 4B HAS USED REASONABLE EFFORTS TO ACCURATELY ILLUSTRATE AND DESCRIBE THE PRODUCTS IN ITS CATALOGS, LITERATURE, AND WEBSITES, SUCH ILLUSTRATIONS AND DESCRIPTIONS ARE FOR THE SOLE PURPOSE OF PRODUCT IDENTIFICATION AND DO NOT EXPRESS OR IMPLY A WARRANTY AFFIRMATION OF FACT, OF ANY KIND OR A WARRANTY OR AFFIRMATION OF FACT THAT THE PRODUCTS WILL CONFORM TO THEIR RESPECTIVE ILLUSTRATIONS OR DESCRIPTIONS. 4B EXPRESSLY DISCLAIMS ANY WARRANTY OR AFFIRMATION OF FACT, EXPRESSED OR IMPLIED, OTHER THAN AS SET FORTH IN THE EXCLUSIVE WRITTEN LIMITED WARRANTY STATEMENT ABOVE, INCLUDING, WITHOUT LIMITATION, THE IMPLIED WARRANTIES OF MERCHANTABILITY AND FITNESS FOR A PARTICULAR PURPOSE.

### 4. LIMITATION OF DAMAGES

ANY LIABILITY FOR CONSEQUENTIAL, INCIDENTAL, SPECIAL, EXEMPLARY, OR PUNITIVE DAMAGES, OR FOR LOSS OF PROFIT WHETHER DIRECT OR INDIRECT, IS EXPRESSLY DISCLAIMED.



4B COMPONENTS  
625 Erie Avenue  
Morton, Illinois 61550  
USA  
Tel: 309-698-5611  
Fax: 309-698-5615  
Web: www.go4b.com

4B BRAIME ELEVATOR  
COMPONENTS  
Hunslet Road  
Leeds, LS10 1JZ  
England  
Tel: +44 (0) 113 246 1800  
Fax: +44 (0) 113 243 5021  
Web: www.go4b.com

4B SETEM  
9 Route de Corbie  
80800 Lamotte Warfusée  
France  
Tel: +33 (0) 3 22 42 32 26  
Fax: +33 (0) 3 22 42 37 33  
Web: www.go4b.com



## BINSWITCH CAPACITANCE POINT LEVEL SWITCH



## INSTALLATION INSTRUCTIONS

## OPERATION MANUAL

BINSWITCH - PART NO's. BS1V3FC, BS1V4FC, BS1V6FC

[www.go4b.com](http://www.go4b.com)

Dear 4B Customer:

Congratulations on your purchase. 4B appreciates your business and is pleased you have chosen our products to meet your needs.

Please read in its entirety and understand the literature accompanying the product before you place the product into service. Please read the safety precautions carefully before operating the product. With each product you purchase from 4B, there are some basic but important safety considerations you must follow to be sure your purchase is permitted to perform its design function and operate properly and safely, giving you many years of reliable service. Please read and understand the Customer Safety Responsibilities listed below. Failure to follow this safety directive and the Operation Manuals and other material furnished or referenced, may result in serious injury or death.

#### ***SAFETY NOTICE TO OUR CUSTOMERS***

- A. In order to maximize efficiency and safety, selecting the right equipment for each operation is vital. The proper installation of the equipment, and regular maintenance and inspection is equally important in continuing the proper operation and safety of the product. The proper installation and maintenance of all our products is the responsibility of the user unless you have asked 4B to perform these tasks.
- B. All installation and wiring must be in accordance with Local and National Electrical Codes and other standards applicable to your industry. (Please see the article "Hazard Monitoring Equipment Selection, Installation and Maintenance" at [www.go4b.com](http://www.go4b.com).) The installation of the wiring should be undertaken by an experienced and qualified professional electrician. Failure to correctly wire any product and/or machinery can result in the product or machine failing to operate as intended, and can defeat its design function.
- C. Periodic inspection by a qualified person will help assure your 4B product is performing properly. 4B recommends a documented inspection at least annually and more frequently under high use conditions.
- D. Please see the last page of this manual for all warranty information regarding this product.

#### ***CUSTOMER SAFETY RESPONSIBILITIES***

##### **1. READ ALL LITERATURE PROVIDED WITH YOUR PRODUCT**

Please read all user, instruction and safety manuals to ensure that you understand your product operation and are able to safely and effectively use this product.

##### **2. YOU BEST UNDERSTAND YOUR NEEDS**

Every customer and operation is unique, and only you best know the specific needs and capabilities of your operation. Please call the 24-hour hotline at 309-698-5611 for assistance with any questions about the performance of products purchased from 4B. 4B is happy to discuss product performance with you at any time.

## **BINSWITCH ACCESSORIES**

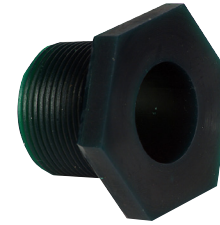

#### **BMPA MOUNT**

Urethane compression fitting mount with 1-1/4" NPT external thread



#### **BAS ABRASION SHIELD**

Urethane abrasion shield/mount for high-abrasion or liquid applications



#### **SMP MOUNTING PLATE**

Powder coated mild steel with 1-1/4" NPT coupling



#### **BSM3 CLAMP MOUNT**

HDP clamp style mount



#### **A34NPT CONDUIT ADAPTER**

Anodized aluminum 30 mm to 3/4" NPT conduit adapter



#### **BMPG36 GLAND MOUNT**

Plastic gland mount

## STANDARD WIRING DIAGRAM

Contacts Shown in  
De-Energized Condition

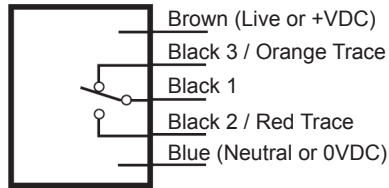

## SENSOR CALIBRATION

1. The unit must be installed before calibration takes place, connect the Binswitch to power and a suitable control unit
2. Check that no material is around the tip of the Binswitch
3. Carefully turn the calibration control screw fully counterclockwise until red LED is "ON". This will set the sensor sensitivity to zero.

NOTE: The total sensitivity setting of the control screw is four full rotations (clockwise and counterclockwise). To prevent damage to the control screw, the screw will continue to rotate after four full rotations.

4. With no material around the tip of the Binswitch, rotate the control screw clockwise until the LED goes "OFF". Then slowly rotate the control screw counterclockwise until the LED goes "ON". Finally, to set the sensor sensitivity to the optimum setting, turn the control screw ten degrees counterclockwise.
5. Start the process to cover the Binswitch with material and check that the red LED goes "OFF" and that the Binswitch shuts down the equipment as required.
6. Remove the material from the Binswitch and check that the red LED comes "ON" and that the Binswitch operates the equipment as required.
7. The Binswitch is now set and ready for use.

NOTE: Turning the control screw counterclockwise decreases the sensor sensitivity, turning clockwise increases the sensitivity.

## NOTICE - DUSTY MATERIAL

If the material being monitored creates dust, you may need to re-calibrate the sensor. Dust build up on the Binswitch will affect the initial calibration. Do NOT remove the Binswitch and clean off the dust. To adjust the sensor to the dust build up, turn the control screw slowly counterclockwise until the LED turns "ON".

*Warning: Always check that the Binswitch detects material after the sensitivity has been adjusted.*

## TESTING AND COMMISSIONING

1. Check that the unit is correctly installed (see standard wiring diagram).
2. After going through the sensor calibration steps, the red LED should be "ON".
3. Introduce material to the Binswitch. If calibrated correctly, the Binswitch will activate when material has been detected. Machinery shut down will depend on your specific monitoring setup. 4B recommends an instant shutdown when maximum fill level or a plug condition has been detected.

## ⚠ WARNING

If the system does not immediately shutdown as expected or alarm as required, then remove the machine from service until the problem has been diagnosed and corrected.

## 3. SELECT A QUALIFIED AND COMPETENT INSTALLER

Correct installation of the product is important for safety and performance. If you have not asked 4B to perform the installation of the unit on your behalf, it is critical for the safety of your operation and those who may perform work on your operation that you select a qualified and competent electrical installer to undertake the installation. The product must be installed properly to perform its designed functions. The installer should be qualified, trained, and competent to perform the installation in accordance with Local and National Electrical Codes, all relevant OSHA Regulations, as well as any of your own standards and preventive maintenance requirements, and other product installation information supplied with the product. You should be prepared to provide the installer with all necessary installation information to assist in the installation.

## 4. ESTABLISH AND FOLLOW A REGULAR MAINTENANCE AND INSPECTION SCHEDULE FOR YOUR 4B PRODUCTS

You should develop a proper maintenance and inspection program to confirm that your system is in good working order at all times. You will be in the best position to determine the appropriate frequency for inspection. Many different factors known to the user will assist you in deciding the frequency of inspection. These factors may include but are not limited to weather conditions; construction work at the facility; hours of operation; animal or insect infestation; and the real-world experience of knowing how your employees perform their jobs. The personnel or person you select to install, operate, maintain, inspect or perform any work whatsoever, should be trained and qualified to perform these important functions. Complete and accurate records of the maintenance and inspection process should be created and retained by you at all times.

## 5. RETAIN AND REFER TO THE OPERATION MANUAL FOR 4B'S SUGGESTED MAINTENANCE AND INSPECTION RECOMMENDATIONS

As all operations are different, please understand that your specific operation may require additional adjustments in the maintenance and inspection process essential to permit the monitoring device to perform its intended function. Retain the Operation Manual and other important maintenance and service documents provided by 4B and have them readily available for people servicing your 4B equipment. Should you have any questions, please call the free 24-hour hotline number (309-698-5611).

## 6. SERVICE REQUEST

If you have questions or comments about the operation of your unit or require the unit to be serviced please contact the 4B location who supplied the product or send your request via fax (309-698-5615) or call us via our 24-hour hotline number in the USA (309-698-5611). Please have available product part numbers, serial numbers, and approximate date of installation. In order to assist you, after the product has been placed into service, complete the online product registration section which is accessed via our website [www.go4b.com](http://www.go4b.com).

## INTRODUCTION

The Binswitch Sensor detects level or plug situations for bulk granular solids or liquids in tanks, bins, or silos and can be used as a plug or choke detector in chutes, conveyors and elevator legs. A two color LED shows material present or absent. The polycarbonate housing is corrosion and abrasion resistant, dust-tight, and waterproof.

## SPECIFICATIONS

Model Power Supply -	12 VDC (BS1V3FC) / 24 VDC (BS1V4FC) / 110 to 240 VAC (BS1V6FC)
Supply Tolerance -	-15% to +10%
Power Consumption -	30 mA
Fuse -	5 amp maximum
Operating Temperature -	-22°F (-30°C) to 158°F (70°C)
Sensing Range -	1" (25 mm) typical
Output -	Voltage free relay: 1 pole normally open, 1 pole normally closed
Contact Rating -	3 amp, 240 VAC, non-inductive
Fail Safe -	Relay reverts to de-energized state on power failure
Calibration Control -	Screw potentiometer (Bin must be empty when calibrating)
LED Indication -	Red on - material absent, Red off - material present
Cable -	6 ft. (2 m) - 5 x 20 AWG conductors
Enclosure -	Polycarbonate
Weight -	10.5 ounces
Protection -	IP67 - NEMA 6 and 6P (dust tight and water resistant)
Approval -	CSA Class II Division 1 Groups E, F and G (ATEX available)

## DIMENSIONS

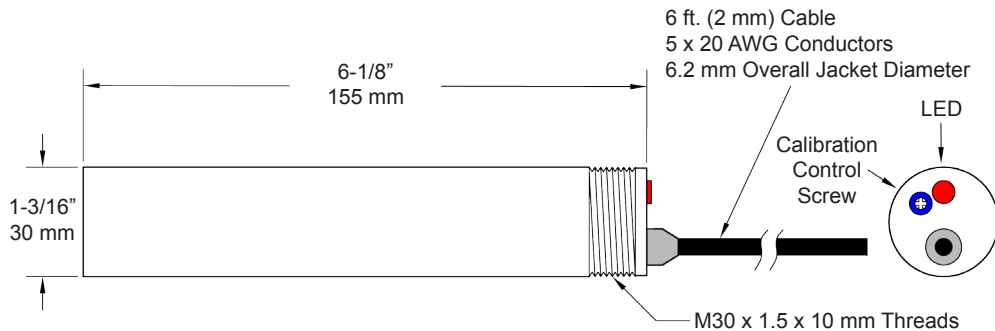

## INSTALLATION

The Binswitch may be mounted horizontally or vertically. 4B offers two mounts, SMP or the BMPG36 (see illustrations below). If the Binswitch must be located in the path of an abrasive material, use in conjunction with the Binswitch Abrasion Shield (BAS). It is important that the Binswitch is not located in the direct flow path of any abrasive material.

Three alternative mounting methods are available for the Binswitch, see Fig. A, B and C below:

Fig. A -

Cut and drill holes as shown and attach mounting plate (SMP) using six 5/16" x 3/4" (M8 x 20) bolts, nuts and washers or use existing mounting plate. Slide Binswitch into position and secure by tightening mounting plate adaptor (BMPA).

**DO NOT OVERTIGHTEN**

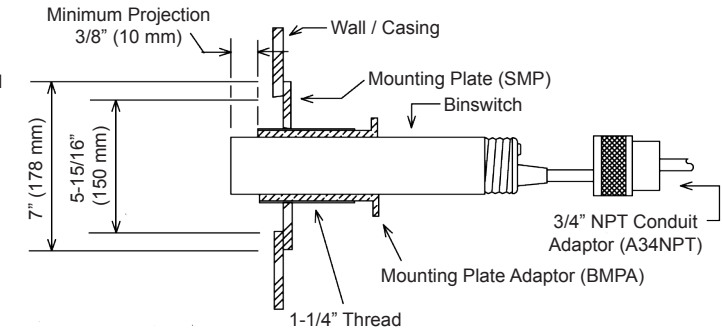

Fig. B -

Cut holes as shown and attach mounting gland (BMPG36) using locknut. Slide binswitch into position and secure using clamp.

**DO NOT OVERTIGHTEN**

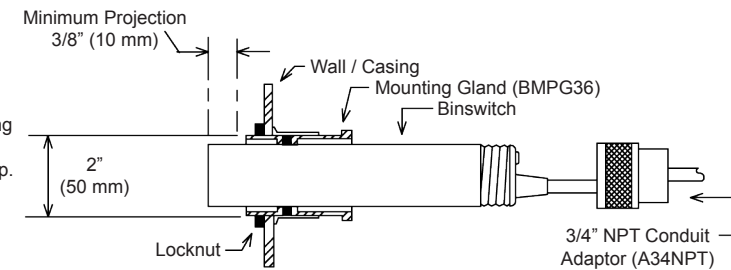

Fig. C -

Cut and drill holes as shown and attach mounting plate (SMP) using six 5/16" x 3/4" (M8 x 20) bolts, nuts and washers or use existing mounting plate. Slide Binswitch into abrasion shield (BAS) and tighten BAS into mounting plate (BMPA).

**DO NOT OVERTIGHTEN**

