



P8001/P8002 Proxswitch

INDUCTIVE PROXIMITY SENSOR



C US
APPROVED
Class II Div. 1

INSTALLATION INSTRUCTIONS



OPERATION MANUAL

Part No's. P8001V34FC, P8002V10FC

www.go4b.com/usa

TABLE OF CONTENTS

CUSTOMER SAFETY RESPONSIBILITIES	Page 4 - 5
PRODUCT OVERVIEW	Page 6
SPECIFICATIONS	Page 6
DIMENSIONS	Page 7
INSTALLATION	Page 7
STANDARD WIRING DIAGRAM	Page 8
TESTING & COMMISSIONING	Page 9
TROUBLESHOOTING GUIDE	Page 10
PRODUCT WARRANTY	Page 11

 	 WARNING
	<p>Rotating parts can crush, cut and entangle.</p> <p>Do NOT operate with guard removed.</p> <p>Lockout power before removing guard or servicing.</p>

Dear 4B Customer:

Congratulations on your purchase. 4B appreciates your business and is pleased you have chosen our products to meet your needs.

Please read in its entirety and understand the literature accompanying the product before you place the product into service. Please read the safety precautions carefully before operating the product. With each product you purchase from 4B, there are some basic but important safety considerations you must follow to be sure your purchase is permitted to perform its design function and operate properly and safely, giving you many years of reliable service. Please read and understand the Customer Safety Responsibilities listed below. Failure to follow this safety directive and the Operation Manuals and other material furnished or referenced, may result in serious injury or death.

SAFETY NOTICE TO OUR CUSTOMERS

- A. In order to maximize efficiency and safety, selecting the right equipment for each operation is vital. The proper installation of the equipment, and regular maintenance and inspection is equally important in continuing the proper operation and safety of the product. The proper installation and maintenance of all our products is the responsibility of the user unless you have asked 4B to perform these tasks.
- B. All installation and wiring must be in accordance with Local and National Electrical Codes and other standards applicable to your industry. (Please see the article “Hazard Monitoring Equipment Selection, Installation and Maintenance” at www.go4b.com.) The installation of the wiring should be undertaken by an experienced and qualified professional electrician. Failure to correctly wire any product and/or machinery can result in the product or machine failing to operate as intended, and can defeat its design function.
- C. Periodic inspection by a qualified person will help assure your 4B product is performing properly. 4B recommends a documented inspection at least annually and more frequently under high use conditions.
- D. Please see the last page of this manual for all warranty information regarding this product.

CUSTOMER SAFETY RESPONSIBILITIES

1. READ ALL LITERATURE PROVIDED WITH YOUR PRODUCT

Please read all user, instruction and safety manuals to ensure that you understand your product operation and are able to safely and effectively use this product.

2. YOU BEST UNDERSTAND YOUR NEEDS

Every customer and operation is unique, and only you best know the specific needs and capabilities of your operation. Please call the 24-hour hotline at 309-698-5611 for assistance with any questions about the performance of products purchased from 4B. 4B is happy to discuss product performance with you at any time.

3. SELECT A QUALIFIED AND COMPETENT INSTALLER

Correct installation of the product is important for safety and performance. If you have not asked 4B to perform the installation of the unit on your behalf, it is critical for the safety of your operation and those who may perform work on your operation that you select a qualified and competent electrical installer to undertake the installation. The product must be installed properly to perform its designed functions. The installer should be qualified, trained, and competent to perform the installation in accordance with Local and National Electrical Codes, all relevant OSHA Regulations, as well as any of your own standards and preventive maintenance requirements, and other product installation information supplied with the product. You should be prepared to provide the installer with all necessary installation information to assist in the installation.

4. ESTABLISH AND FOLLOW A REGULAR MAINTENANCE AND INSPECTION SCHEDULE FOR YOUR 4B PRODUCTS

You should develop a proper maintenance and inspection program to confirm that your system is in good working order at all times. You will be in the best position to determine the appropriate frequency for inspection. Many different factors known to the user will assist you in deciding the frequency of inspection. These factors may include but are not limited to weather conditions; construction work at the facility; hours of operation; animal or insect infestation; and the real-world experience of knowing how your employees perform their jobs. The personnel or person you select to install, operate, maintain, inspect or perform any work whatsoever, should be trained and qualified to perform these important functions. Complete and accurate records of the maintenance and inspection process should be created and retained by you at all times.

5. RETAIN AND REFER TO THE OPERATION MANUAL FOR 4B'S SUGGESTED MAINTENANCE AND INSPECTION RECOMMENDATIONS

As all operations are different, please understand that your specific operation may require additional adjustments in the maintenance and inspection process essential to permit the monitoring device to perform its intended function. Retain the Operation Manual and other important maintenance and service documents provided by 4B and have them readily available for people servicing your 4B equipment. Should you have any questions, please call the free 24-hour hotline number (309-698-5611).

6. SERVICE REQUEST

If you have questions or comments about the operation of your unit or require the unit to be serviced please contact the 4B location who supplied the product or send your request via fax (309-698-5615) or call us via our 24-hour hotline number in the USA (309-698-5611). Please have available product part numbers, serial numbers, and approximate date of installation. In order to assist you, after the product has been placed into service, complete the online product registration section which is accessed via our website www.go4b.com/usa.

WARNING

- Rotating machinery can cause serious injury or death
- Always lockout and tagout the machine prior to installation

PRODUCT OVERVIEW

The P800 Proxswitch is an inductive sensor designed to detect shaft speed, shaft position, gate position, or object presence.

The P800 Proxswitch is a CSA Class II, Division 1 approved limit switch style proximity sensor, which works on the damped oscillator principle. No contact is made between the sensor and the object being monitored. The P800 will detect a ferrous object at 1/2" and a non-ferrous metal object at a distance of 5/16".

Two different Sensor outputs are available. One with changeover relay contact outputs which works on a supply voltage of 24 to 240 VAC / 12 to 240 VDC and another with solid state NPN/PNP transistor outputs which works on a supply voltage of 10 to 30 VDC.

Both units are fully encapsulated and come with a 6 foot cable lead and 1/2 inch conduit entry. Two LED's show power supply and input status.

SPECIFICATIONS

	P8001V34FC	P8002V10FC
Supply Voltage -	10 to 30 VDC	12 to 240 VDC / 24 to 240 VAC
Output -	NPN/PNP transistor rated at 30 VDC 100 mA max.	Voltage free change over relay 3A 240V max.
Output State -	Selected by supply polarity connection	Output de-energized (off) with no target
Max. Input Speed -	250 Hz (15,000 PPM)	5 Hz (300 PPM)
Indication -	Red and green LED's for target detection	
Operating Temperature -	-13°F (-25°C) to 158°F (70°C)	
Sensing Range -	Ferrous target - 1/2 inch (12 mm) maximum Non-ferrous target - 5/16 inch (6 mm) maximum	
Enclosure -	Nylon	
Conduit Entry -	1/2 inch NPT	
Cable Length -	6 ft. (2 m)	
Weight -	1 lb.	
Protection -	IP67	
Approvals -	CSA Class II Div 1 Groups E, F and G (USA and Canada) CE (Europe)	

DIMENSIONS

ALL DIMENSIONS IN INCHES

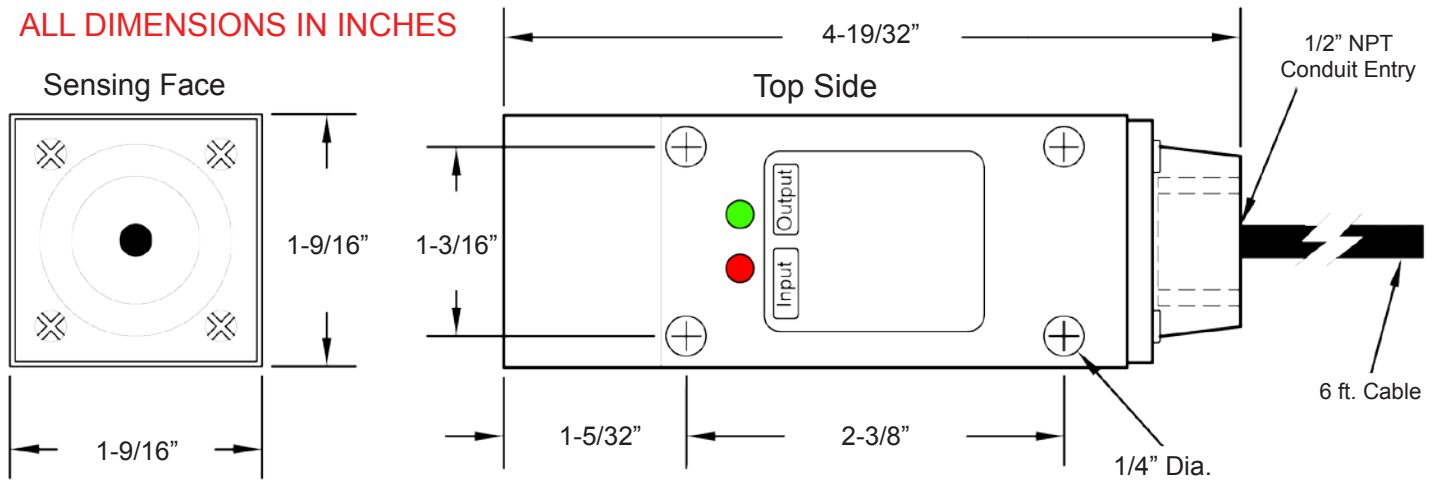

INSTALLATION

The P800 should be wired as shown in the connections diagram on page 8. The two P800 models have different connections, so make sure to use the correct diagram for your model.

Cable length can be extended to virtually any distance required. The proximity sensor is well protected against electrical interference, but if long cable runs are used in very noisy environments, the cabling should be segregated from any high current carrying conductors.

The sensing face of the sensor, should overhang at least 1-1/4 inches (31 mm) from any metalwork that the unit is fixed to, otherwise the unit will stay in the "ON" state. Ensure that any background metalwork, behind the target to be sensed, is at least 5/8 inches (15 mm) behind the target. This will prevent the proximity sensor from detecting that background metalwork. Illustration A below denotes sensing ranges for ferrous and non-ferrous targets.

NOTE - Red LED (input) indicates target sensed, and green LED (output) indicates output on. LED's are located on the top side of the P800 (Illustration A).

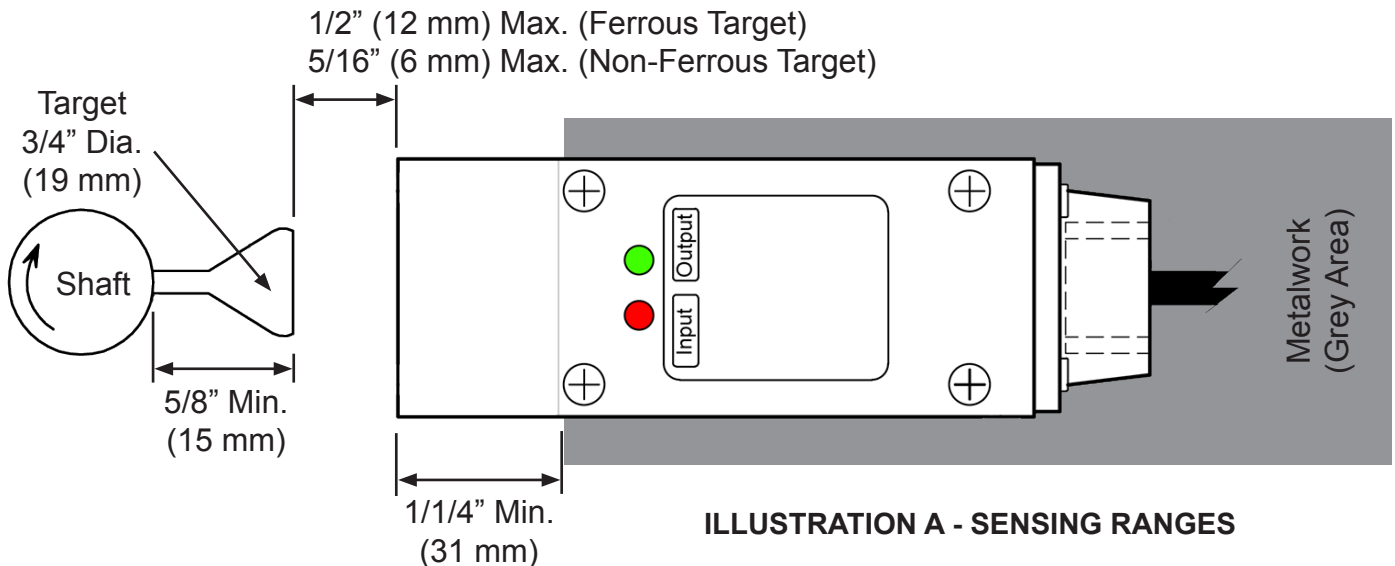

ILLUSTRATION A - SENSING RANGES

Ensure all connections are correct before applying power. Apply power to the P800 and machinery, then check that the input and output LEDs are flashing "ON" and "OFF" indicating the target is being sensed.

⚠ WARNING

O.S.H.A. requires that all exposed rotating shafts are provided with a full guard. Therefore, this device and its target must be equipped with a guard.

Fasten the P800 to a suitable mounting bracket, such as 4B's Whirligig® universal shaft sensor mount, with the nose of the switch within the sensing range of the target, as shown below -

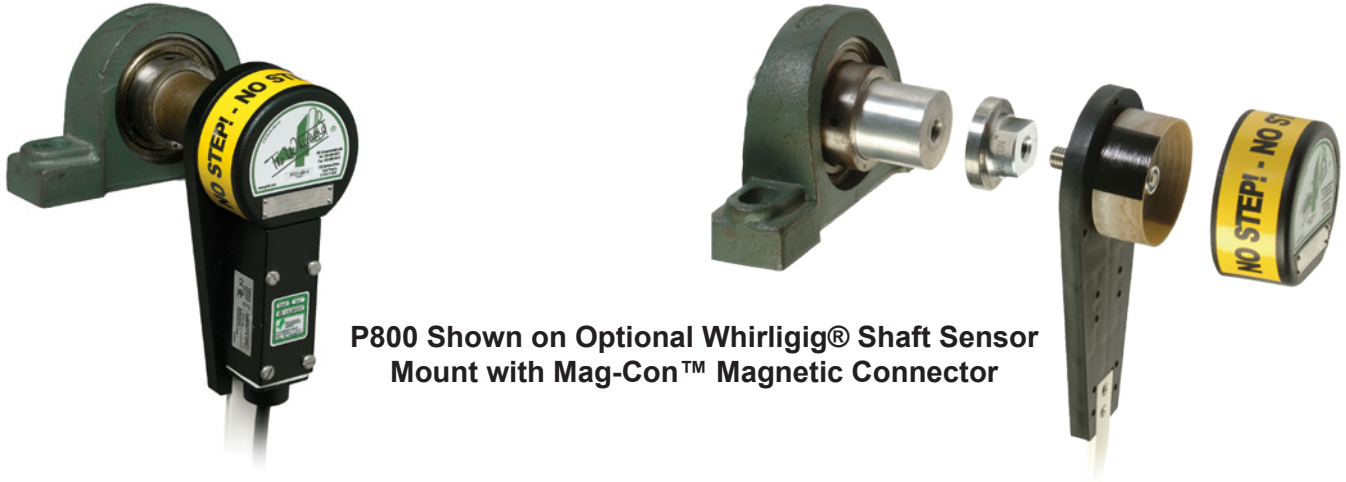

P800 Shown on Optional Whirligig® Shaft Sensor Mount with Mag-Con™ Magnetic Connector

STANDARD WIRING DIAGRAM

All wiring must be in accordance with local and national electrical codes and should be undertaken by an experienced and qualified electrician.

Always use dust/liquid tight flexible metal conduit with approved fittings to protect the sensor cables. Use rigid metal conduit to protect the cables from the sensors to the control unit. Conduit systems can channel water due to ingress and condensation directly to sensors and sensor connections which over time will adversely affect the performance of the system. As such, the installation of low point conduit drains is recommended for all sensors.

P8001V34FC

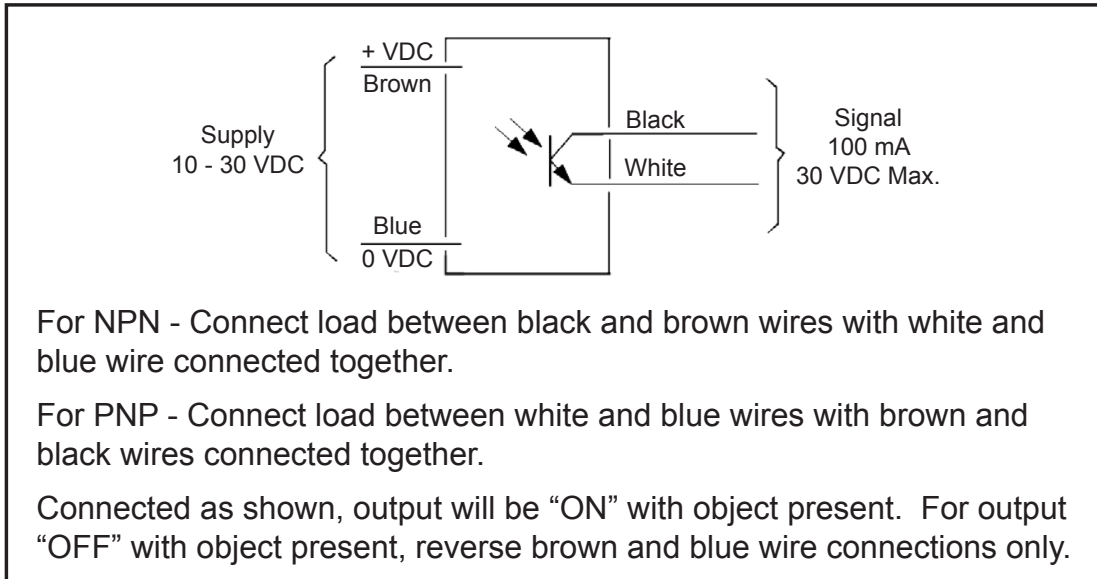

P8002V10FC

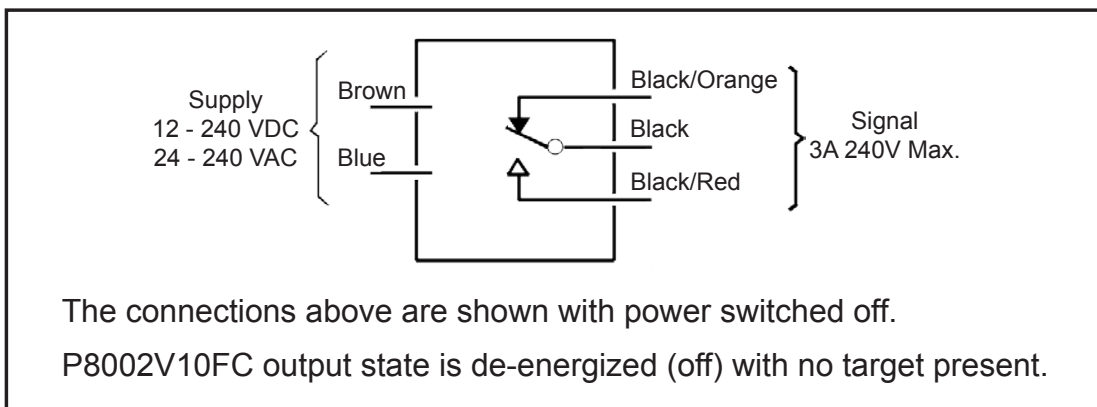

TESTING AND COMMISSIONING

1. Check that the unit is correctly installed (see standard wiring diagram).
2. Check that the distance between the target, stud or bolt head and sensing face of P800 is within the minimum distance specified.
3. Start up machine.
4. If monitoring for speed see A, for proximity monitoring see B -
 - A. If the P800 is being used to monitor speed, 4B's *SpeedMaster™* calibration and testing device can be used to insure the P800 shuts down the machine at the correct percentage of slip. Shut down will depend on your specific monitoring setup. 4B recommends an instant shutdown on any belts slipping 20% or more of normal speed.
 - B. If the P800 is being used as a proximity switch, be sure that the target is not within range of the sensor prior to testing. Use a metal putty knife or a small piece of metal and place it between the sensing face of the P800 and the target. This will cause the sensor to energize the output, and both the green and red LEDs will go on. Removing the putty knife will de-energize the output signal and both LEDs will go off.

SPEEDMASTER™



Patents -
US8947073
MX321802
EP26223568

The *SpeedMaster™* with Pulse Pilot is the only device that accurately tests the calibration of a speed switch, and allows testing of the alarm and shutdown features of the sensor while installed on the machine shaft.

The *SpeedMaster™* operates in two modes. Input mode is used to measure the pulse rate at normal speed. Output mode will allow the user to input pulses to the sensor for testing purposes.

The Pulse Pilot fits between the gap between the sensor and the target. The Pulse Pilot will have no effect on the operation of the speed switch until it is connected to the *SpeedMaster™* and set to “output” mode.

⚠ WARNING

If the system does not immediately shutdown as expected or alarm as required, then remove the machine from service until the problem has been diagnosed and corrected.

TROUBLESHOOTING GUIDE

FAULT	REMEDY
Input and Output LED's Stay "ON"	<ul style="list-style-type: none"> • Check that the sensing face of the sensor is not bolted directly to metalwork
	<ul style="list-style-type: none"> • Check that there is a space between the sensor face and any surrounding metalwork (1-1/4 inches - 31 mm minimum)
	<ul style="list-style-type: none"> • Check that the machinery is rotating and that the target is actually leaving the sensor before reappearing
	<ul style="list-style-type: none"> • Check that background metalwork, behind target, is far enough away so as not to be detected
Input and Output LED's Stay "OFF"	<ul style="list-style-type: none"> • Check supply voltage to the sensor.
	<ul style="list-style-type: none"> • Check that target is within specified operating range of unit.
	<ul style="list-style-type: none"> • Check that machinery is rotating and that target is passing the sensing face of the sensor.

PRODUCT WARRANTY

1. EXCLUSIVE WRITTEN LIMITED WARRANTY

ALL PRODUCTS SOLD ARE WARRANTED BY THE COMPANY (4B COMPONENTS LIMITED, (4B) BRAIME ELEVATOR COMPONENTS LIMITED, AND (4B) S.E.T.E.M. Srl) HEREIN AFTER REFERRED TO AS 4B TO THE ORIGINAL PURCHASER AGAINST DEFECTS IN WORKMANSHIP OR MATERIALS UNDER NORMAL USE FOR ONE (1) YEAR AFTER DATE OF PURCHASE FROM 4B. ANY PRODUCT DETERMINED BY 4B AT ITS SOLE DISCRETION TO BE DEFECTIVE IN MATERIAL OR WORKMANSHIP AND RETURNED TO A 4B BRANCH OR AUTHORIZED SERVICE LOCATION, AS 4B DESIGNATES, SHIPPING COSTS PREPAID, WILL BE, AS THE EXCLUSIVE REMEDY, REPAIRED OR REPLACED AT 4B'S OPTION.

2. DISCLAIMER OF IMPLIED WARRANTY

NO WARRANTY OR AFFIRMATION OF FACT, EXPRESSED OR IMPLIED, OTHER THAN AS SET FORTH IN THE EXCLUSIVE WRITTEN LIMITED WARRANTY STATEMENT ABOVE IS MADE OR AUTHORIZED BY 4B. 4B SPECIFICALLY DISCLAIMS ANY LIABILITY FOR PRODUCT DEFECT CLAIMS THAT ARE DUE TO PRODUCT MISUSE, ABUSE OR MISAPPLICATIONS, AS AUTHORIZED BY LAW, 4B SPECIFICALLY DISCLAIMS ALL WARRANTIES THAT THE PRODUCT IS FIT OR MERCHANTABLE FOR A PARTICULAR PURPOSE.

3. NO WARRANTY "BY SAMPLE OR EXAMPLE"

ALTHOUGH 4B HAS USED REASONABLE EFFORTS TO ACCURATELY ILLUSTRATE AND DESCRIBE THE PRODUCTS IN ITS CATALOGS, LITERATURE, AND WEBSITES, SUCH ILLUSTRATIONS AND DESCRIPTIONS ARE FOR THE SOLE PURPOSE OF PRODUCT IDENTIFICATION AND DO NOT EXPRESS OR IMPLY A WARRANTY AFFIRMATION OF FACT, OF ANY KIND OR A WARRANTY OR AFFIRMATION OF FACT THAT THE PRODUCTS WILL CONFORM TO THEIR RESPECTIVE ILLUSTRATIONS OR DESCRIPTIONS. 4B EXPRESSLY DISCLAIMS ANY WARRANTY OR AFFIRMATION OF FACT, EXPRESSED OR IMPLIED, OTHER THAN AS SET FORTH IN THE EXCLUSIVE WRITTEN LIMITED WARRANTY STATEMENT ABOVE, INCLUDING, WITHOUT LIMITATION, THE IMPLIED WARRANTIES OF MERCHANTABILITY AND FITNESS FOR A PARTICULAR PURPOSE.

4. LIMITATION OF DAMAGES

ANY LIABILITY FOR CONSEQUENTIAL, INCIDENTAL, SPECIAL, EXEMPLARY, OR PUNITIVE DAMAGES, OR FOR LOSS OF PROFIT WHETHER DIRECT OR INDIRECT, IS EXPRESSLY DISCLAIMED.

With subsidiaries in North America, Europe, Asia, Africa and Australia along with a worldwide network of distributors, 4B can provide practical solutions for all your applications no matter the location.



4B BRAIME ELEVATOR COMPONENTS

Hunslet Road
Leeds
LS10 1JZ
United Kingdom
Tel: +44 (0) 113 246 1800
Fax: +44 (0) 113 243 5021

4B DEUTSCHLAND

9 Route de Corbie
Lamotte Warfusée
F-80800
France
Tel: +49 (0) 700 2242 4091
Fax: +49 (0) 700 2242 3733

4B ASIA PACIFIC

Build No. 899/1 Moo 20
Soi Chongsiri, Bangplee-Tam Ru Road,
Tanbon Bangpleeyai, Amphur Bangplee,
Samutprakarn 10540
Thailand
Tel: +66 (0) 2 173-4339
Fax: +66 (0) 2 173-4338

4B COMPONENTS LTD.

625 Erie Avenue
Morton, IL 61550
USA
Tel: 309-698-5611
Fax: 309-698-5615

4B SETEM SARL

9 Route de Corbie
80800 Lamotte Warfusée
France
Tel: +33 (0) 3 22 42 32 26
Fax: +33 (0) 3 22 42 37 33

4B AFRICA

14 Newport Business Park
Mica Drive, Kya Sand
2163 Johannesburg
South Africa
Tel: +27 (0) 11 708 6114
Fax: +27 (0) 11 708 1654

4B AUSTRALIA

Unit 1/18 Overlord Place
Acacia Ridge
Queensland 4110
Australia
Tel: +61 (0) 7 3711 2565
Fax: +61 (0) 7 3711 2574

www.go4b.com