

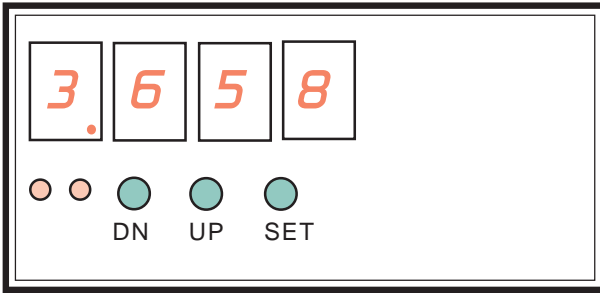

A multifunction display unit which can be end user programmed to indicate Speed, Rate or Time intervals. The unit incorporates a 4 digit red LED display with programmable auto decimal point, in a DIN 96x48mm enclosure (panel cut-out size: 92x44mm). A relay output is provided for Speed control use. Select your **function** from Chart ①, ② & ③. Select **program** as detailed overleaf ⑤.

**UNIT/FUNCTION SETTING**

Carefully remove front bezel to access controls.  
 Connect as shown in ④



**CONNECTIONS**

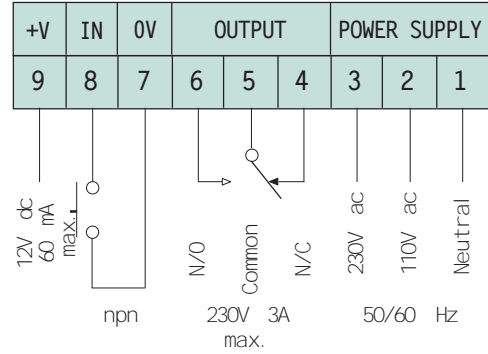

Note: Relay energises above or below 'Trip Level' setting. See overleaf for programming details.

④

DISPLAY	FUNCTION
① nod0	Tachometer (Revolutions/Min. RPM)
nod1	Tachometer (Revolutions/Sec. RPS)
nod2	Tachometer (Revolutions/Hr. RPH)
nod3	Line Speed Indicator (Metres/Min.M/Min)
nod4	Line Speed Indicator (Yards/Min. Yd/Min)
#nod5	Interval/Duty Timer (Seconds.)
② r.00.1	Response Time (Range 0.1 - 99.9 mS)
③ dp.A	Decimal Point (Auto position)
dp.N	No Decimal Point
dp.1	1 Decimal Point
<b>Set using DN/UP keys/buttons.</b>	

**FUNCTION SETTINGS**

To enter program mode, press & hold 'DN' button for 3 sec. Do not press 'DN' or 'UP' buttons except where shown. Subsequent presses of the 'SET' button will index to the next function.

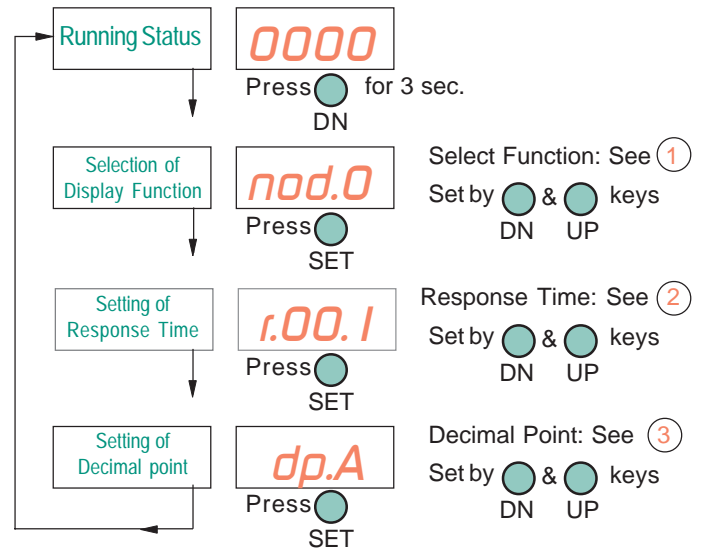

**Dimensions**

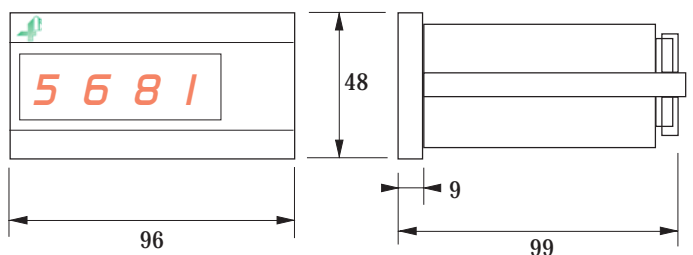

## PROGRAM/DATA SETTINGS

To enter program mode, press & hold 'SET' button for 3 sec. Subsequent presses of the 'SET' button will index to the next function.

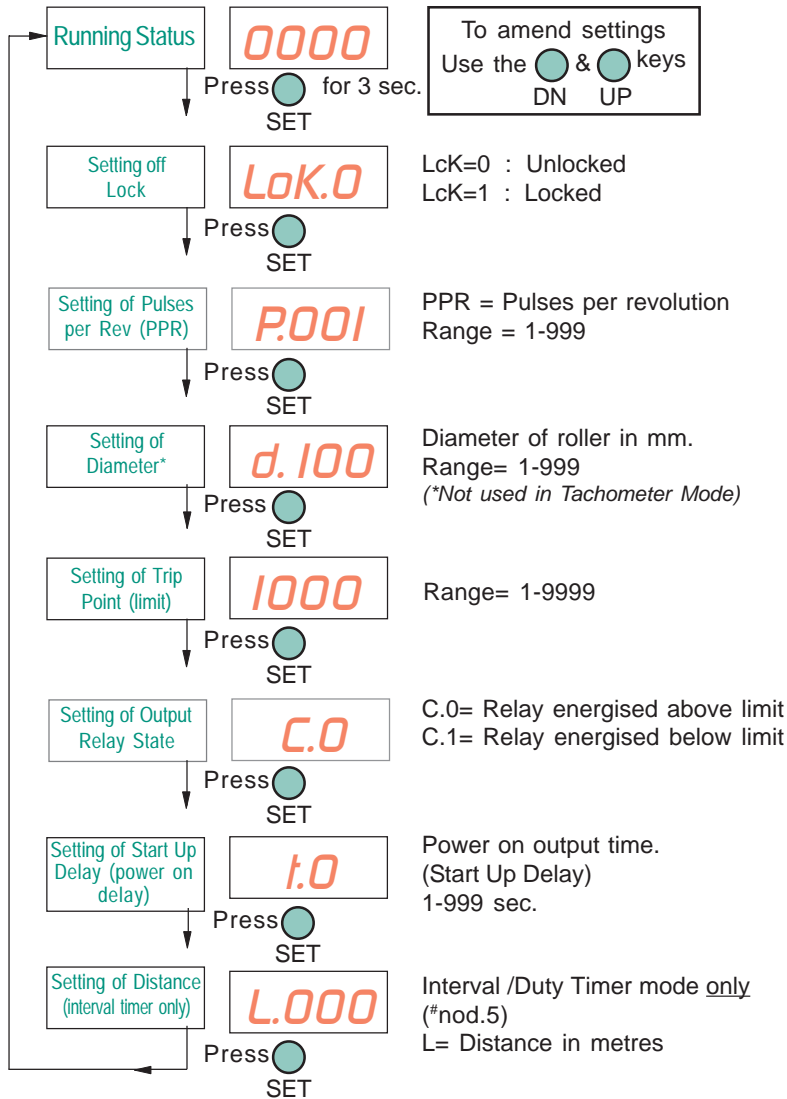

Record your Unit Settings below:

### FUNCTION SETTINGS:

display function: nod \_\_\_\_\_

response time: \_\_\_\_\_ mSec.

decimal point: dp \_\_\_\_

### PROGRAM/DATA SETTINGS:

lock setting: LcK. \_\_\_\_\_

pulses per revolution: P. \_\_\_\_\_

\*diameter setting: d. \_\_\_\_\_ (not used in tachometer mode)

trip point (limit): \_\_\_\_\_

output relay state: C. \_\_\_\_\_

start up delay: t. \_\_\_\_\_

#distance: L. \_\_\_\_\_ (interval/duty timer mode only)

### Notes