

WDB7 Series

Lug Style Surface Temperature Sensor

APPLICATION

For use on any application where surface temperature monitoring is desired or required.

METHOD OF OPERATION

The WDB7 series is a lug style NTC thermistor model for continuous temperature monitoring and has been designed to bolt directly onto a bearing housing, motor, gearbox, or machine casing. The mounting hole is 5/16" from the factory, but can be drilled up to 1/2" if needed. The sensor can be connected to a PLC or to a hazard monitoring system, such as 4B's T500 Hotbus Elite, Watchdog Elite, or T400 Elite. The connections are not polarity sensitive therefore special connections requirements are eliminated. The WDB7 series is approved for use in Class II, Div 1 Groups E, F, and G dust hazard locations.

FEATURES

- ▶ Surface Mount Installation
- ▶ 5/16" to 1/2" Bolt Entry
- ▶ 1/2" NPT Conduit Entry
- ▶ Continuous Temperature Monitoring

PART NUMBERS

- ▶ WDB70V3C – Surface Mount Style Bearing Sensor



WDB70V3C



Detailed specification, wiring diagrams and installation/operating instructions available immediately upon request.

Please refer to instruction manual for correct installation. Information subject to change or correction. March 2008.

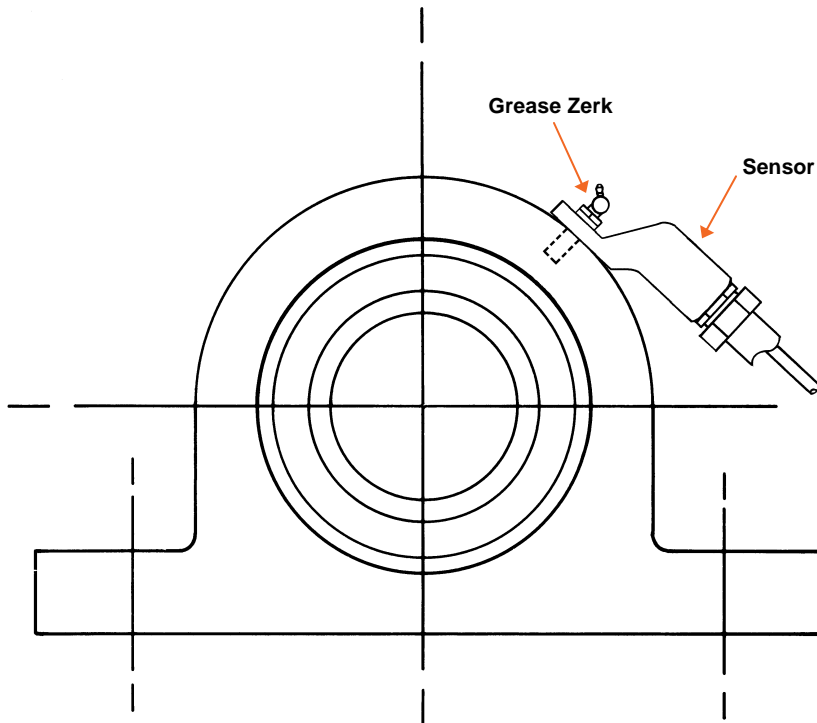

Installation of Lug Style Temperature Sensor on the Surface of a Bearing



WDB70V3C Installed on Bearing Housing

TECHNICAL SPECIFICATIONS

WDB7 Series Surface Temperature Sensor

WDB Series 7	
Resistance at 77°F:	10,000 Ohms
Resistance at 140°F:	2,487 Ohms
Resistance at 194°F:	916 Ohms
Sensing Voltage:	5 to 24 VDC
Current Draw:	1 ma
Conduit Entry:	1/2" NPT
Fixed Entry Hole:	5/16" Factory (Can Be Drilled Up To 1/2")
Cable:	2 Core + Drain Wire (9ft. Long)
Protection:	Class 2 Div 1 Groups E, F, G Approved (US and Canada)



Example of Bearing Failure

Temperature Sensors can be used with the following 4B Hazard Monitoring Systems



T500 Hotbus Elite



Watchdog Elite



T400 Elite

Please refer to instruction manual for correct installation. Information subject to change or correction. March 2008.